

SECTION 8200 – ACHD STORMWATER DESIGN TOOLS AND APPROVED BMPS

8200	ACHD STORMWATER DESIGN MANUAL	1
8201	INTRODUCTION.....	1
8201.1	PURPOSE OF THIS MANUAL.....	1
8201.2	MODIFICATIONS AND ADDENDA	1
8202	DESIGN TOOLS AND RESOURCES	1
8202.1	INTENSITY DURATION FREQUENCY CURVE (IDF CURVE).....	1
8202.2	ACHD STORMWATER DESIGN SPREADSHEET	1
8202.3	INFILTRATION TESTING METHODS.....	2
8202.4	OPERATION AND MAINTENANCE (O&M) PLAN OUTLINE	2
8202.5	FACILITY REVEGETATION AND IRRIGATION.....	2
8202.6	INSPECTION CHECKLISTS.....	3
8202.7	DESIGN DETAILS	3
8202.8	LIST OF APPROVED STORMWATER BMPS	3
8202.9	BMP ALTERNATIVES	3
	<i>8202.9.1 When a new technology or BMP is proposed, the Applicant shall submit to ACHD, prior to plan submittal A description of the alternative technology or BMP</i>	<i>4</i>
	<i>8202.9.2 Data on the effectiveness of the alternative technology.....</i>	<i>4</i>
	<i>8202.9.3 Validation Information.....</i>	<i>4</i>
8202.10	DESIGN CRITERIA FOR MANUFACTURED SYSTEMS.....	4
8202.11	OTHER RESOURCES	4
8202.12	BMP 01 SAND AND GREASE TRAP (PRETREATMENT)	6
8202.13	BMP 02 TREATMENT AND CONVEYANCE SWALE (PRETREATMENT).....	7
8202.14	BMP 03 GRASS BUFFER STRIP (PRETREATMENT)	9
8202.15	BMP 04 CONCRETE CATCH MANHOLE (PRETREATMENT).....	11
8202.16	BMP 05 MANUFACTURED SYSTEMS (PRETREATMENTS).....	12
8202.17	REQUIREMENTS FOR BASINS.....	13
	<i>8202.17.1 Definitions.....</i>	<i>13</i>
	<i>8202.17.2 Side Slopes</i>	<i>13</i>
	<i>8202.17.3 Freeboard.....</i>	<i>13</i>
	<i>8202.17.4 Outfall Pipe Armoring</i>	<i>13</i>
	<i>8202.17.5 Forebays & Primary Storage Basin.....</i>	<i>13</i>
	<i>8202.17.6 Dams and Embankments.....</i>	<i>13</i>
	<i>8202.17.7 Emergency Overflows/Flood Routing</i>	<i>14</i>
	<i>8202.17.8 Design Requirements for Detention Basins</i>	<i>14</i>

	8202.17.8.1 Maximum Outflow Rate for Detention Basins	14
	8202.17.8.2 Outlets for Detention Basins	14
	8202.17.9 Basin Liners	15
	8202.17.10 General Landscape Guidelines for Stormwater Basins	16
	8202.17.11 Maintenance	16
	8202.17.12 License Agreement	16
8202.18	BMP 10 INFILTRATION BASIN WITH FOREBAY (PRETREATMENT, TREATMENT & STORAGE).....	16
8202.19	BMP 11 DETENTION BASIN WITH FOREBAY (PRETREATMENT, TREATMENT & STORAGE) .	19
8202.20	BMP 12 DETENTION BASIN WITH UNDERDRAIN (PRETREATMENT, TREATMENT & STORAGE).....	21
8202.21	BMP 13 WET RETENTION OR DETENTION BASIN (PRETREATMENT, TREATMENT & STORAGE).....	23
8202.22	BMP 14 CONSTRUCTED WETLAND BASIN (TREATMENT & STORAGE).....	25
8202.23	BMP 20 SEEPAGE BED WITH OPTIONAL CHAMBERS (TREATMENT & STORAGE)	27
8202.24	BMP 21 VERTICAL SAND FILTER	32
8202.25	BMP 22 UNDERGROUND SAND FILTER VAULT (PRETREATMENT, TREATMENT)	35
8202.26	REQUIREMENTS FOR BIORETENTION FACILITES	37
	8202.26.1 Description	37
	8202.26.2 Siting.....	37
	8202.26.3 General Design Criteria.....	37
	8202.26.4 Flow Regulation.....	38
	8202.26.5 Storage Layer.....	38
	8202.26.6 Bioretention Soil Media (BSM)	38
	8202.26.7 Vegetation/Mulch.....	39
8202.27	BMP 30 BIORETENTION SWALE (TREATMENT & STORAGE).....	40
8202.28	BMP 31 BIORETENTION PLANTER	44
8202.29	BMP 32 BIORETENTION CURB EXTENSION (TREATMENT & STORAGE)	47
8202.30	BMP 33 STORMWATER TREE CELLS.....	50
8202.31	BMP 34 PERMEABLE PAVERS (TREATMENT & STORAGE).....	56
APPENDIX A	62
Ada County IDF Curve	63
APPENDIX B	64
Infiltration Testing Methods	64
APPENDIX C	68
Operations & Maintenance Plan	69
APPENDIX D	70
ACHD Basin Revegetation Guidance Manual	70

APPENDIX E..... 71
Basin Inspection Checklist 72
APPENDIX F..... 76
Bioretention Soil Media Specifications..... 77
APPENDIX G 81
Detail 1 Beehive Overflow 1 of 1..... 82
Detail 2 Flow Spreader for Basins and Swales sheet 1 of 1 83
Detail 3 Access Roads and Turnaround Detail sheet 1 of 2 84
Detail 4 ACHD Basin Standards sheet 1 of 2..... 86
Detail 5 Borrow Ditch sheet 1 of 1..... 88
Detail 6 Drop Inlet Layout Tolerances sheet 1 of 1..... 89
Detail 7 Seepage Bed/Sewer & Water Service Conflict sheet 1 of 1 90

8200 ACHD STORMWATER DESIGN MANUAL

8201 INTRODUCTION

8201.1 Purpose of This Manual

The ACHD Stormwater Design Manual and Approved BMPs (referred to herein as the Manual) provides the tools and guidance needed for designers and plan reviewers to select, design, and review stormwater systems within the jurisdiction of the ACHD. This manual is a supplement to the ACHD Section 8000 Stormwater Policy (referred to herein as the Policy).

These standards may or may not apply in all situations. Compliance with these standards does not relieve the applicant of the responsibility to use sound professional judgment to comply with all local, state, or federal requirements. ACHD intends for these standards to assist, but not substitute for, competent work by design professionals.

8201.2 Modifications and Addenda

This Manual will be updated to include advances in engineering and Best Management Practices (BMPs). The designer should check the website at www.achdidaho.org to verify they have the most current version.

8202 DESIGN TOOLS AND RESOURCES

8202.1 Intensity Duration Frequency Curve (IDF Curve)

See Appendix A for the current Intensity Duration Frequency Curve to be used for Ada County.

8202.2 ACHD Stormwater Design Spreadsheet

ACHD has developed a Microsoft Excel spreadsheet to help establish consistency and assist in the review of stormwater calculations. A completed spreadsheet shall be submitted with the civil plans for ACHD review. The spreadsheet is not intended to replace the Idaho Licensed Design Professional's calculation methods or relieve the Idaho Licensed Design Professional of responsibility for the design calculations. The purpose of the spreadsheet is to provide the review technician with a familiar presentation of the data so that the review process is more efficient. The spreadsheet is available on the ACHD website or from the Stormwater Section upon request.

ACHD may approve an Idaho Licensed Design Professional's alternative format to the spreadsheet if the volume and peak flow calculations are summarized for each storage facility and the calculations meet or exceed the ACHD calculated minimum values. Computer software printouts that are not summarized by storage facility and do not contain a narrative explaining the methodology will not be accepted.

8202.3 Infiltration Testing Methods

8202.4 Appendix B provides a description of approved infiltration testing methods.
Operation and Maintenance (O&M) Plan Outline

The outline provided in Appendix C shall be used for Operation and Maintenance plans.

8202.5 Facility Revegetation and Irrigation

Native grasses and drought-tolerant plant species are recommended for use in surface stormwater facilities for water quality treatment, slope stabilization and erosion control. Native plant species should be specified over non-native species except for native trees which may not be well suited to stormwater facilities. Salt resistant vegetation should be used in locations with probable adjacent salt application.

ACHD stormwater basins shall be landscaped according to the “Ada County Highway District Stormwater Management Basin Revegetation Guidance Manual” (October 2017) in Appendix D. Bioretention planters shall be landscaped according to ACHD’s “Plant Materials for Bioretention Facilities in the Right-of-Way”.

If the ACHD Stormwater Facilities are designed with BMP(s) requiring vegetation as a component of the BMP(s), the Developer shall be responsible for the establishment of all vegetation in the ACHD Stormwater Facilities within the warranty period. To ensure adequate vegetation establishment meeting the requirements of the selected BMP(s) the Developer shall enter into an improvement agreement with the District and post a minimum \$5,000 warranty bond (or provide another financial surety acceptable to ACHD) through the warranty period. If the vegetation has not established within the warranty period, the Developer shall be required to request an extension of the improvement agreement and take the necessary steps to remedy the deficiency. Facilities maintained by a Homeowner’s Association are subject to ACHD review and approval of design and landscaping through plan review and approval of a License Agreement.

Non-draining materials like rocks and cobbles are prohibited over the infiltration areas because they prevent proper infiltration. If turf grass is used, only washed sod, sod grown on sandy soils or use of hydroseeding shall be allowed on the areas designed to infiltrate and barriers shall be used to protect the infiltration areas from other sodded areas until the vegetation is established.

Provide irrigation for native plant establishment (2-3 years), and supplemental irrigation during periods of prolonged drought. Reclaimed water shall not be used for irrigation in stormwater facilities.

8202.6 Inspection Checklists

ACHD has developed a checklist for inspection of stormwater basins. This checklist is in Appendix E and is available for download from the ACHD website or by contacting the Environmental Department.

8202.7 Design Details

The following miscellaneous design details shall be used for stormwater design plans. They are included in Appendix F.

Detail 1 Beehive Overflow

Detail 2 Flow Spreader for Basins and Swales

Detail 3 Access Roads and Turnaround Detail

Detail 4 Stormwater Basin Standards

Detail 5 Borrow Ditch

Detail 6 Drop Inlet Layout Tolerances

Detail 7 Seepage Bed/Water Service Conflict Options

8202.8 List of Approved Stormwater BMPs

This section lists ACHD's approved Best Management Practices (BMPs). The title of each BMP has a description of the functions for which the BMP is approved including Pretreatment, Treatment, and Storage.

Infiltration facilities with landscape-based treatment are recommended over detention facilities and manufactured systems.

Facilities that infiltrate to groundwater must comply with Idaho Groundwater Standards and IDWR Rules for Waste Disposal and Injection Wells. Facilities that discharge to surface water must comply with water quality protection criteria based on Idaho Water Quality Standards and applicable water quality plans.

8202.9 BMP Alternatives

The District may require more stringent requirements than would normally be required under these standards depending on special conditions and/or environmental constraints for a given site. ACHD has the option of accepting alternative BMPs to these standards if the proposed alternatives meet or exceed the adopted performance standards.

ACHD encourages the development of innovative practices that meet the intent of ACHD's stormwater policy and design standards. If new practices meet or exceed these standards in the future, ACHD may adopt the practice for general use.

Stormwater facilities and controls other than those identified in this Manual may be proposed (or as recommended by the Development & Technical Services Deputy Director) where site constraints make it difficult to achieve the stormwater management standards with conventional systems where a new technology may provide a higher level of treatment or performance.

8202.9.1 When a new technology or BMP is proposed, the applicant shall submit to ACHD, prior to plan submittal, a description of the alternative technology or BMP including:

- a. Size
- b. Technical description including mechanism used for pollutant removal
- c. Capital costs
- d. Design life
- e. Installation process and costs (describe consequences if installed improperly, etc.)
- f. Minimum and recommended operation and maintenance (O&M) requirements and costs

8202.9.2 Data on the effectiveness of the alternative technology:

- a. Data from laboratory testing and pilot or full scale operation, and calculation of pollutant removal rates for pollutants of concern (POC) sediment (TSS), total phosphorus (TP), dissolved ortho-phosphorus (DOP), and bacteria (*E. coli*)
- b. Operational details on any full-scale installations, including any special licensing, hauling, or access requirements, and safety issues associated with the operation and maintenance of the product.

8202.9.3 Validation Information:

- a. Articles from peer review, scientific, or engineering journals
- b. Any approvals or permits from other authorities
- c. A monitoring plan to demonstrate BMP effectiveness or clear representations of the specific pollutant removal efficiencies for the device in a typical mode of use and under conditions that would be expected normally within the jurisdiction.
- d. References and examples of actual installations of the product

ACHD staff will assess proprietary system pollutant removal based on the manufacturer's test data at the design flow rate and at the median concentration for the POCs (TSS, TP, DOP, *E. coli*) typically found for this region or similar regions.

8202.10 Design Criteria for Manufactured Systems

All use of manufactured or prefabricated stormwater treatment systems is subject to review and prior approval by the District. ACHD approval is dependent on the product being used and tested in other areas with a proven record of effectiveness and maintainability.

8202.11 Other Resources

ACHD may consider BMPs listed on the following agency websites for pretreatment or primary treatment.

Washington Department of Ecology

<http://www.ecy.wa.gov/programs/wq/stormwater/newtech/technologies.html>

General BMPs and proprietary manufactured systems.

International Stormwater BMP Database
<http://www.bmpdatabase.org/>
General BMPs and proprietary manufactured systems.

WERF
<http://www.werf.org/>
General BMPs.

New Jersey Stormwater
<http://www.njstormwater.org>
Proprietary manufactured systems.

Idaho Department of Environmental Quality
<http://www.deq.idaho.gov/water-quality/wastewater/stormwater.aspx>
Landscape based treatment BMPs.

8202.12 BMP 01 Sand and Grease Trap (Pretreatment)

Description

BMP01 includes two alternatives for the Sand and Grease Trap:

1. Standard 1000 and 1500 Gallon Sand and Grease Trap Vault,
2. 750 Gallon Catch Basin/Sediment Box (Combo Box).

Note: The use of item 2-Catch Basin/Sediment Box (Combo Box) is only allowed where a standard inlet with Sand and Grease Trap conflicts with utilities. The use of a Catch Basin/Sediment Box requires ACHD approval.

Sand and Grease Traps are approved for use only as pretreatment for seepage beds and sand filters.

Design

See ISPWC and ACHD Supplemental Drawings, SD-624 and SD-606.

Storm conveyance systems shall be designed so the Sand and Grease Trap flows are less than or equal to 0.5-feet per second (fps). A diversion manhole upstream of the sand and grease trap shall divert the high flow around the sand/grease trap

If the total Q is less than 3.33 cfs, one online 1000 gallon tank may be used without a high flow bypass pipe unless otherwise noted with BMP.

<u>Unit</u>	<u>Max Q</u>
1000 Gallon Tank, approx. inside dimension 4'x8'x6' (20" Baffle Spacing)	3.33 cfs
1500 Gallon Tank, approx. inside dimension 5'x7'x7' (20" Baffle Spacing)	4.15 cfs
Catch Basin/Sediment Box, approx. inside dimensions 5.33'x7.5'x3' (8-inch Baffle Spacing)	1.77 cfs

8202.13 BMP 02 Treatment and Conveyance Swale (Pretreatment)

Description

This BMP is approved for pretreatment of stormwater runoff.

Design

For conveyance swales, a hydraulic residence time of 9-minutes is required. Water velocity through the swale, as determined by Manning's "n", should not exceed 0.9 feet/second. The maximum depth of flow through a conveyance swale shall be 4-inches.

Swale side slopes shall be no steeper than 4:1.

For surface flow on streets with curb/gutter, flow shall enter the swale through a Shallow Inlet

Provide for energy dissipation and flow spread using Flow Spreaders, per Detail 2.

The length of swale required for pretreatment:

$$\text{Length} = Q_{WQ}/A_{\text{swale}} \times 540$$

Where:

Length = Length of swale required for treatment (in feet)

Q_{WQ} = Volume of runoff from 2-year, 1-hour event

540 seconds = 9 minutes residence time x 60 sec/min

A_{swale} = Cross sectional area of swale (square feet)

Longitudinal slope of the swale shall be 1% to 2% between velocity dissipation berms. Berms shall be placed at a distance that keeps the velocity at a maximum of 0.9 feet per second.

Light maintenance of this BMP, when approved for use by the District, shall be performed by the developer or a homeowner's association unless it is an ACHD owned facility.

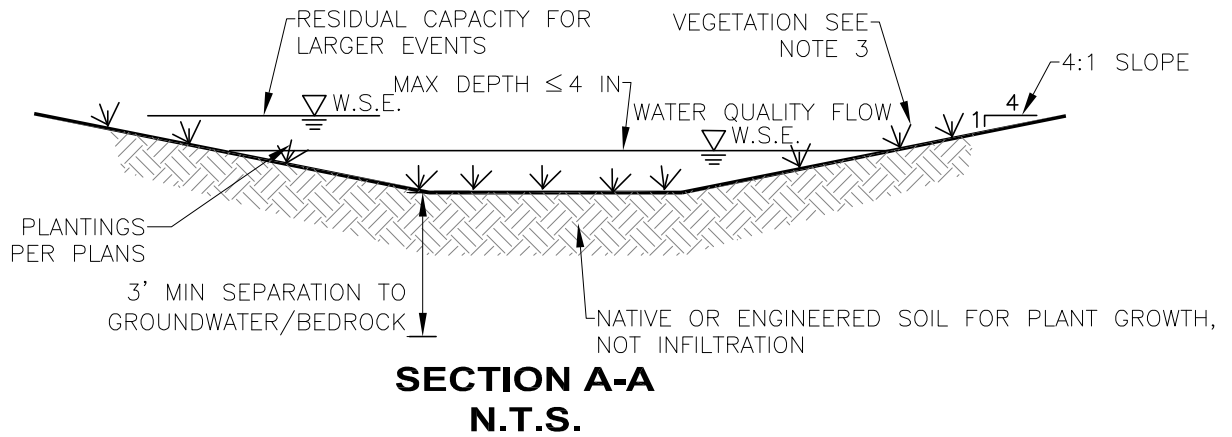
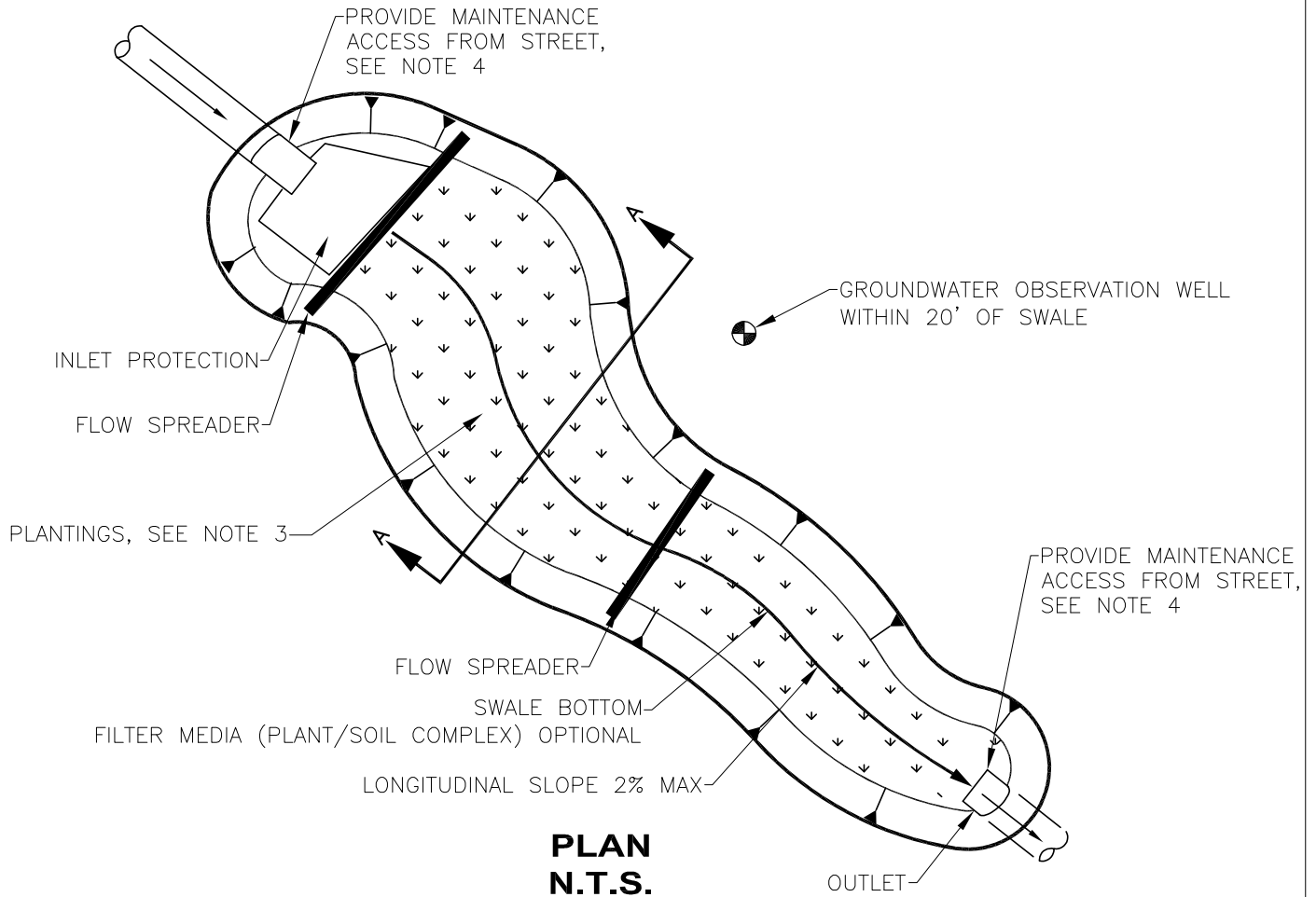

NOTES:

1. SWALE IS DESIGNED FOR CONVEYANCE AND TREATMENT THROUGH PLANT FILTERING. STORMWATER CAN FLOW LONGITUDINALLY IN SWALE. GRADE TO BE MIN 1% TO A MAX OF 2%. SIZE SWALE FOR 2-YR STORM EVENT FOR WATER QUALITY TREATMENT.
2. USE BMP 30 IF INFILTRATION IS DESIRED
3. DROUGHT TOLERANT PLANT SPECIES OR WASHED TURF GRASS
4. PROVIDE MAINTENANCE ACCESS TO ALL PIPES AND STRUCTURES FROM THE STREET

8202.14 BMP 03 Grass Buffer Strip (Pretreatment)

Description

This BMP is approved for pretreatment if flows from roadside runoff are not concentrated in gutter flow or a pipe network. Storage facilities such as a swale or borrow ditch must be provided.

Design

The longest flow path from the area contributing sheet flow to the filter strip shall not exceed 150 feet. The maximum depth of flow through the filter strip for optimum water quality treatment shall be 1.0 inch.

The maximum allowable flow velocity through this BMP shall be 0.5-feet per second.

Buffer strip side slopes shall be no steeper than 3:1.

Grass buffer strips shall not be used when the contributing drainage areas have a longitudinal grade steeper than 5 percent. Energy dissipation and flow spreading shall be provided upslope of the upper edge of the filter strip to achieve flow characteristics equivalent to those meeting the above criteria.

Light maintenance of this BMP, when approved for use by the District, shall be performed by the developer or a homeowner's association unless it is an ACHD owned facility.

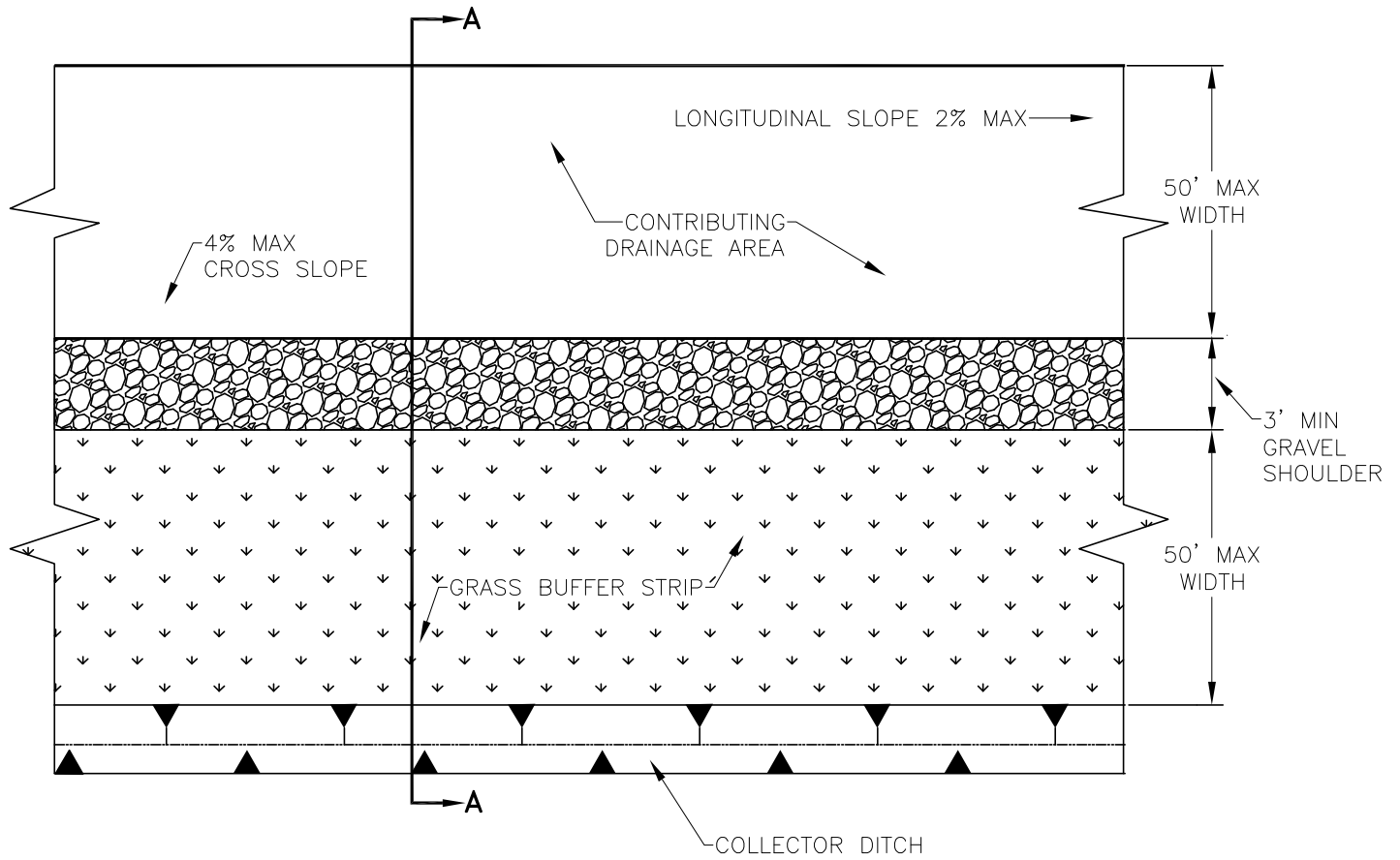

**PLAN
N.T.S.**

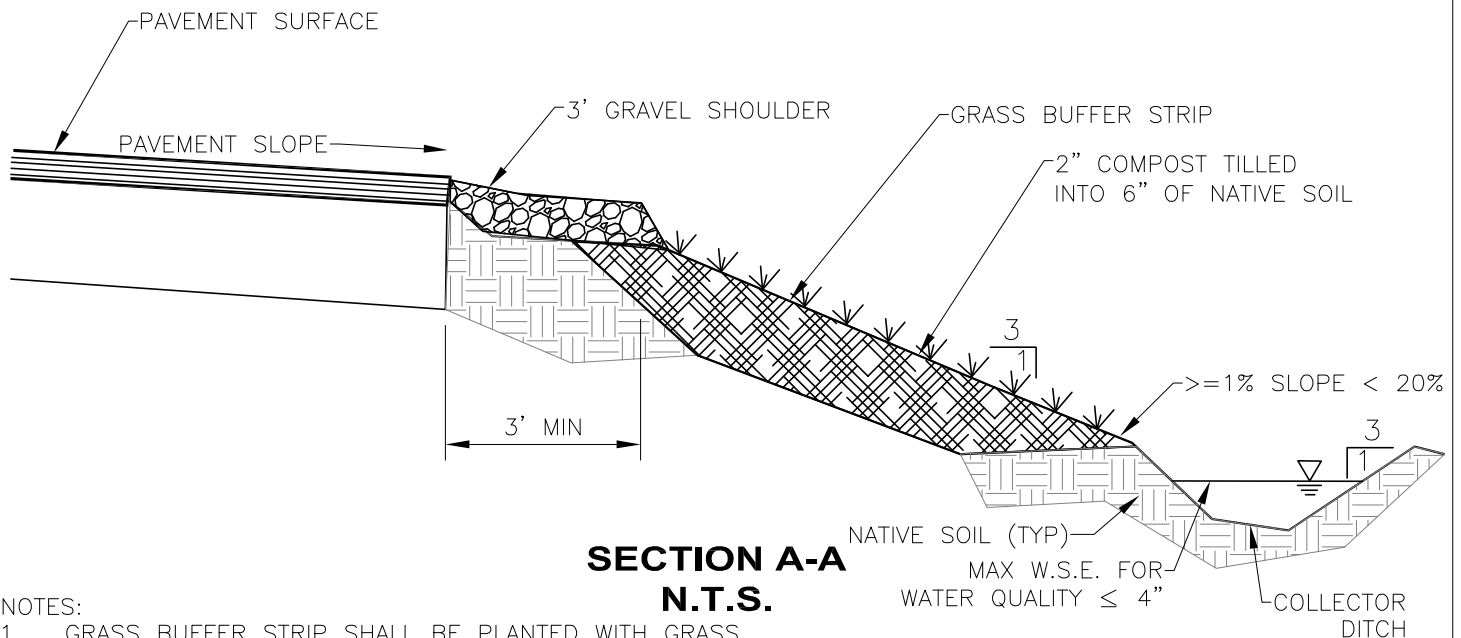

**SECTION A-A
N.T.S.**

NOTES:

1. GRASS BUFFER STRIP SHALL BE PLANTED WITH GRASS

8202.15 BMP 04 Concrete Catch Manhole (Pretreatment)

Description

This BMP is approved for pretreatment only for subsurface BMPs.

Design

See ISPWC and ACHD Supplemental Drawings, SD-611.

8202.16 BMP 05 Manufactured Systems (Pretreatment)

Description

ACHD allows the use of manufactured systems for pretreatment only with written approval.

Design

See Manufacturer's website for design information.

No details are provided for this BMP.

(BMPs 6-9 Reserved)

8202.17 REQUIREMENTS FOR BASINS

8202.17.1 Definitions

A basin is an impoundment created by a dam or an excavation for the purpose of storing water and settling sediment and other pollutants from surface runoff.

A retention basin is designed to hold a specific amount of water until the water can infiltrate.

A detention basin is designed to temporarily hold, or detain, a specified volume of runoff while slowly releasing flows at a controlled rate to a receiving conveyance system.

Following are standards to be used in the design of stormwater basins.

8202.17.2 Side Slopes

Side slopes should be 4:1 (horizontal: vertical), but no greater than 3:1 unless specifically approved by ACHD and the basin is fenced for safety (8202.17.10).

8202.17.3 Freeboard

For facilities up to 3-feet in depth from the basin bottom to high water mark, the minimum freeboard shall be 0.5-feet. For facilities with a pool depth greater than 3-feet, the minimum freeboard shall be 1-foot.

8202.17.4 Outfall Pipe Armoring

Pipe outfalls shall be armored with riprap or an approved flow spreader for energy dissipation and erosion protection.

8202.17.5 Forebays & Primary Storage Basin

All basins shall have a sediment forebay unless otherwise approved by ACHD. Forebays shall be sized to accommodate ten percent (10%) of the total basin volume except in the foothills where forebays shall be sized to accommodate fifteen (15%) of the total basin volume. Exceptions for the forebay and high-flow bypass requirements may be made for basins where the total bottom footprint is less than 1500 square feet.

The forebay shall be separated from the primary storage basin by an earthen berm barrier with side slopes no steeper than 3:1 unless specifically approved by ACHD. Forebays with a bottom footprint of greater than 1500 square feet shall be designed with a maintenance access ramp with not greater than 15% slope. Stormwater in the forebay can be designed to spill over an armored berm into the primary basin.

Stormwater basins shall drain 90% of the design volume in 48-hours unless designed as a wet basin.

8202.17.6 Dams and Embankments

The Idaho Department of Water Resources (IDWR) may categorize a basin as a dam if the vertical distance between the high-water mark and the downstream

flow line exceeds 10-feet or the basin impounds more than 50 acre-feet of water. If a basin meets either criterion, then a permit may be required from the IDWR. Contact IDWR for more information.

Embankment slopes shall be no steeper than 3:1 (horizontal:vertical), preferably 4:1 or less. Embankment soils shall be compacted to 95% of their maximum density at optimum moisture.

An Anti-Seep Collar or other seepage control methods shall be installed around outlet pipes within embankments.

8202.17.7 Emergency Overflows /Flood Routing

The Idaho Licensed Design Professional shall demonstrate the ability to safely pass the 24 hour, 100-year runoff event. The streets can be used to convey or store stormwater runoff with limits on the street carrying capacity based on the classification of the street related to emergency usage during flood events in accordance with Section 8011.5.2.

8202.17.8 Design Requirements for Detention Basins

Detention basins shall be designed to lengthen the flow path, thereby increasing detention time from inlet to outlet. The recommended length to width ratio should be 3:1 or more. Areas within a dry basin that convey water shall have a minimum two percent (2%) slope to mitigate nuisance flows.

The design of a detention facility requires designing the discharge to not adversely impact downstream areas and leave the hydrology the same as existed before development.

Balancing these requirements is done through the development of three items: an inflow hydrograph, a depth-storage relationship, and a depth-outflow relationship. These items are combined in a routing routine to determine the outflow rate, depth of stored water, and volume of storage at any specific time, as the flood passes through the detention facility. The inflow/storage/outflow relationships shall be based on a storm duration that identifies a peak detention basin volume for the storm interval required. The design considerations and procedures are discussed in the following sections.

8202.17.8.1 Maximum Outflow Rate for Detention Basins

The maximum outflow rate should not exceed the pre development flow rate. The receiving system must be shown to be capable of accommodating the design flow and written approval from the owner/operator of the downstream facility is required.

Detention basin outlets shall be designed to pass a flow rate necessary for extended attenuation, normally 48 to 72 hours. The outlet design shall incorporate a multi-stage riser to allow water to be drained over an extended period.

8202.17.8.2 Outlets for Detention Basins

1. To minimize the chance of clogging and to facilitate cleaning, outlet pipes shall be at least 12-inches in diameter.

If riser pipes are used, they shall be at least 1-1/2 times the cross-sectional area of the outfall pipe. Trash racks and anti-vortex devices shall be required. All pipe joints are to be watertight.

2. Outflows shall be staged to not exceed pre-development discharge rates for the 2, 25, and 100-year design flows. Rectangular openings or V-notch weirs are preferred over small round orifices for maintenance purposes. Small orifices must be pre-approved by ACHD and if approved, the minimum orifice opening shall be 3-inches in diameter to help prevent clogging.
3. Outlet structures shall be reinforced concrete. All construction joints are to be watertight.
4. Suitable slope protection approved by the District shall be placed downstream of principal outlets as necessary to prevent scour and erosion. High velocity discharges require energy dissipaters.

8202.17.9 Basin Liners

Liners may be used when designing a wet basin with porous soils. The liner shall be used with a minimum one foot (1') of cover. The following specifications are the minimum requirements for a rigid basin liner. Type D or C Soils, Clay or other impervious liners may also be used upon request and with ACHD written approval.

PVC Liner

Property	Test Method	English
Profile Thickness	ASTM D-1593	30 mil
Specific Gravity	ASTM D792	1.20
Breaking Factor (lbs/in width)(1" wide)	ASTM D-882 Method A or B	73
Elongation at Break (%) (2" jaw separation)	ASTM D-882 Method A or B	350
Modulus (force) at 100% Elongation (lbs/in width)	ASTM D-882 Method A or B	34
Tear Resistance (lbs, min)	ASTM D-1004 (Die C)	8.5
Low Temperature, °C	ASTM 1790	-29
Water Extraction (% loss max)	ASTM D-1204 (as modified by NSF)	0.15
Dimensional Stability (each direction, % change max)	ASTM D-1204	± 3
Volatility Loss (% loss max)	ASTM 1203 Method A	0.7
Breaking Factor	ASTM D-3083 (as modified by NSF)	± 5
Elongation at Break	ASTM D-3083 (as modified by NSF)	± 20
Modulus at 100% Elongation	ASTM D-3083 (as modified by NSF)	± 20
Hydrostatic Resistance (psi min)	ASTM D-751 Method A	100

8202.17.10 General Landscape Guidelines for Stormwater Basins

Vegetation shall be established in the forebay and the primary cell on the basin bottom and slopes for erosion control and pollutant removal. Native grasses and drought tolerant plant species are recommended for use in stormwater facilities for slope stabilization and erosion control. ACHD stormwater basins shall be landscaped according to the "Ada County Highway District Stormwater Management Basin Revegetation Guidance Manual (October 2017) in Appendix D.

Basins maintained by a Homeowner's Association (HOA) are subject to ACHD review and approval of design and landscaping through plan review and approval of a License Agreement.

Basins owned and maintained by ACHD shall be fenced with minimum 4-foot tall fence with a top rail and openings with a maximum separation of four inches (4"), except ACHD reserves the right to review and approve on a case-by-case basis, a fence design that varies from the minimum design criteria herein. Detail 4 in this Design Manual shows the standards for ACHD owned basins. Basins owned and maintained by a Homeowner's Association may be similar to these standards but may not require a fence.

Materials like rocks, cobbles, and sod are prohibited over the infiltration areas.

Washed turf or turf with an approved sandy topsoil mix is allowed over infiltration areas for shared use facilities like ball fields. The design should spread the stormwater out over a large area, so the design storm water depth is shallow. ACHD must approve multi-use facilities through a License Agreement.

8202.17.11 Maintenance

Light maintenance of this facility, when approved for use by the District, shall be performed by the developer or a homeowner's association unless it is an ACHD owned facility.

8202.17.12 License Agreement

As a condition of final plat or plan approval, the Developer is required to obtain a License Agreement for landscaping within ACHD right-of-way and easements. Because stormwater easements are exclusive to ACHD, a License Agreement is required to install landscaping within the exclusive easement (see ACHD Policy Section 4000 for more information).

Stormwater basins can be shared use facilities such as parks or ball fields with a License Agreement. Shared use facilities are encouraged as long as the primary use for stormwater storage, treatment, and maintenance access are not negatively impacted by the secondary use.

8202.18 BMP 10 Infiltration Basin with Forebay (Pretreatment, Treatment & Storage)

Description

This BMP is approved for pretreatment, treatment and storage.

A conventional infiltration basin stores the design storm, treats and infiltrates stormwater with no discharge from the site.

Design

Refer to Section 8202.17 for design requirements.

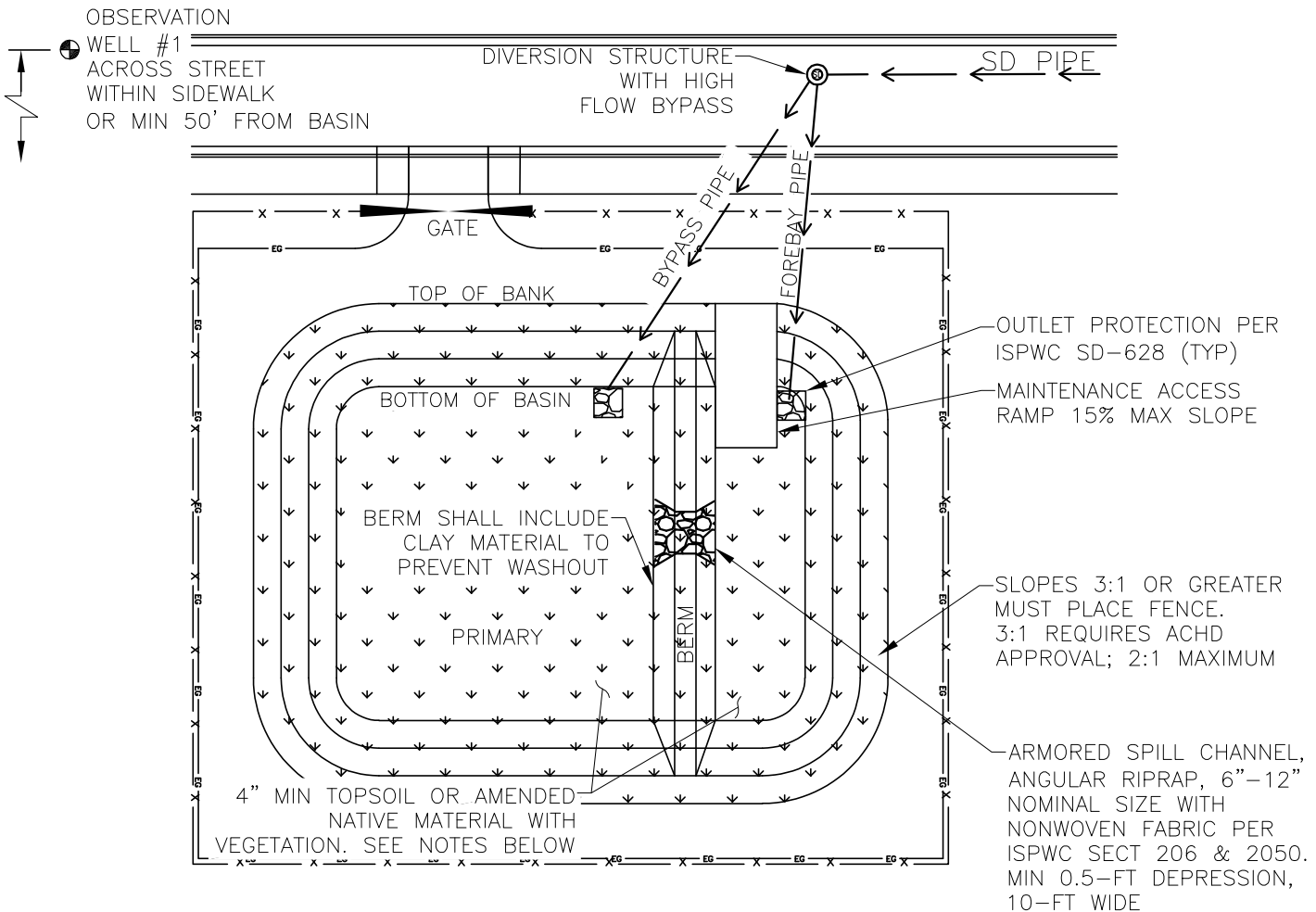

**PLAN VIEW
N.T.S.**

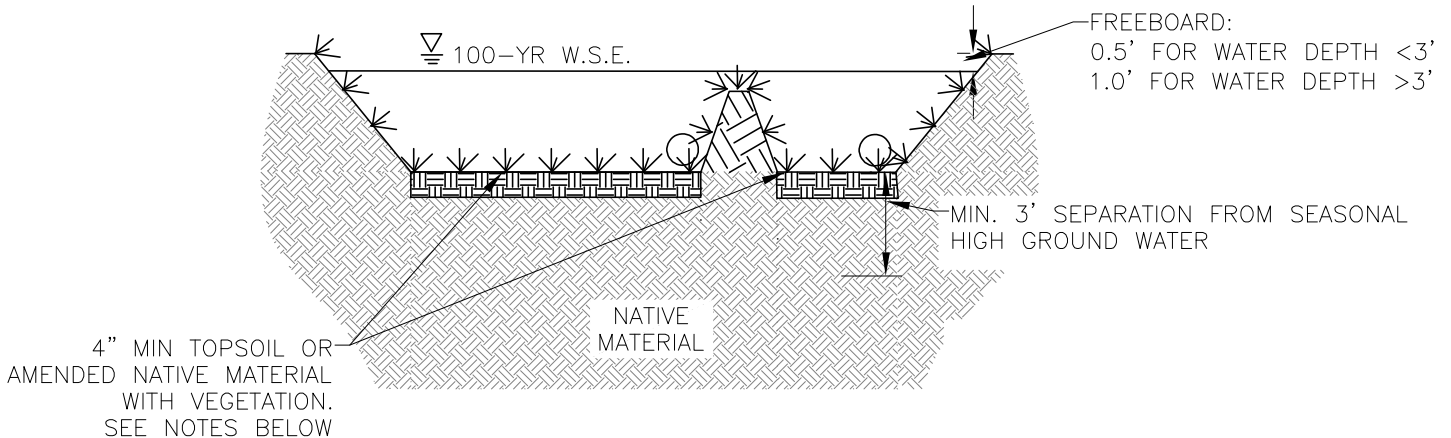

**SECTION
N.T.S.**

NOTES:

1. SEE STORMWATER BASIN STANDARDS DETAIL 4, SHEET 2

8202.19 BMP 11 Detention Basin with Forebay (Pretreatment, Treatment & Storage)

Description

This BMP is approved for pretreatment, treatment and storage.

A conventional detention basin stores the peak design storm, treats and discharges stormwater at a controlled rate to downstream receiving facilities.

Design

Refer to Section 8202.17 for design requirements.

PVC Liner Table moved to Section 8202.17.9

Property	Test Method	English
Profile Thickness	ASTM D-1593	30 mil
Specific Gravity	ASTM D792	1.20
Breaking Factor (lbs/in width)(1" wide)	ASTM D-882 Method A or B	73
Elongation at Break (%) (2" jaw separation)	ASTM D-882 Method A or B	350
Modulus (force) at 100% Elongation (lbs/in width)	ASTM D-882 Method A or B	34
Tear Resistance (lbs, min)	ASTM D-1004 (Die C)	8.5
Low Temperature, °C	ASTM 1790	-29
Water Extraction (% loss max)	ASTM D-1204 (as modified by NSF)	0.15
Dimensional Stability (each direction, % change max)	ASTM D-1204	± 3
Volatility Loss (% loss max)	ASTM 1203 Method A	0.7
Breaking Factor	ASTM D-3083 (as modified by NSF)	± 5
Elongation at Break	ASTM D-3083 (as modified by NSF)	± 20
Modulus at 100% Elongation	ASTM D-3083 (as modified by NSF)	± 20
Hydrostatic Resistance (psi min)	ASTM D-751 Method A	100

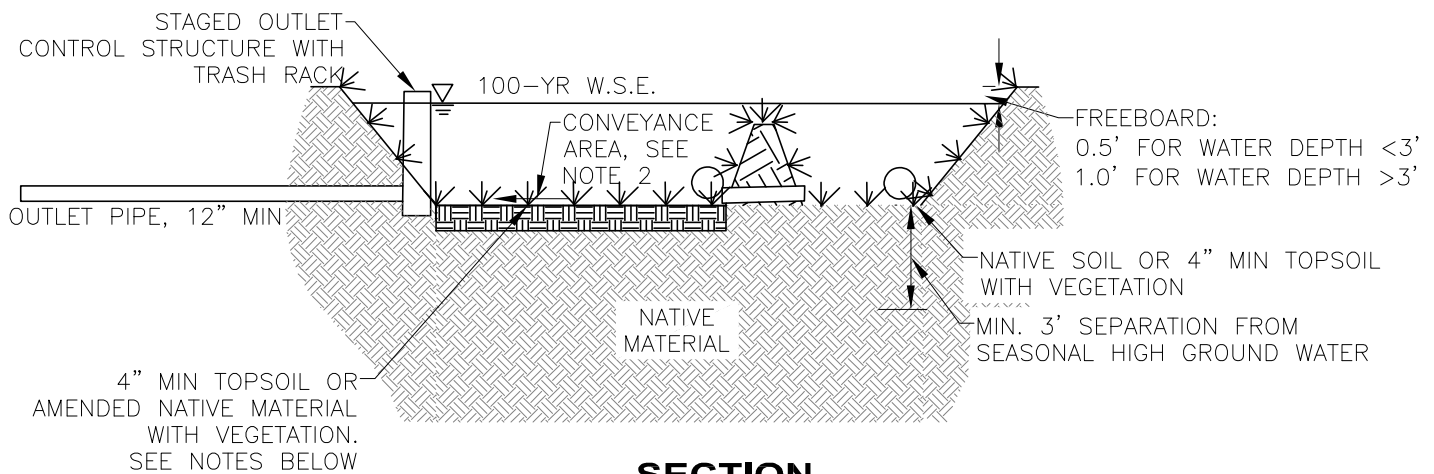
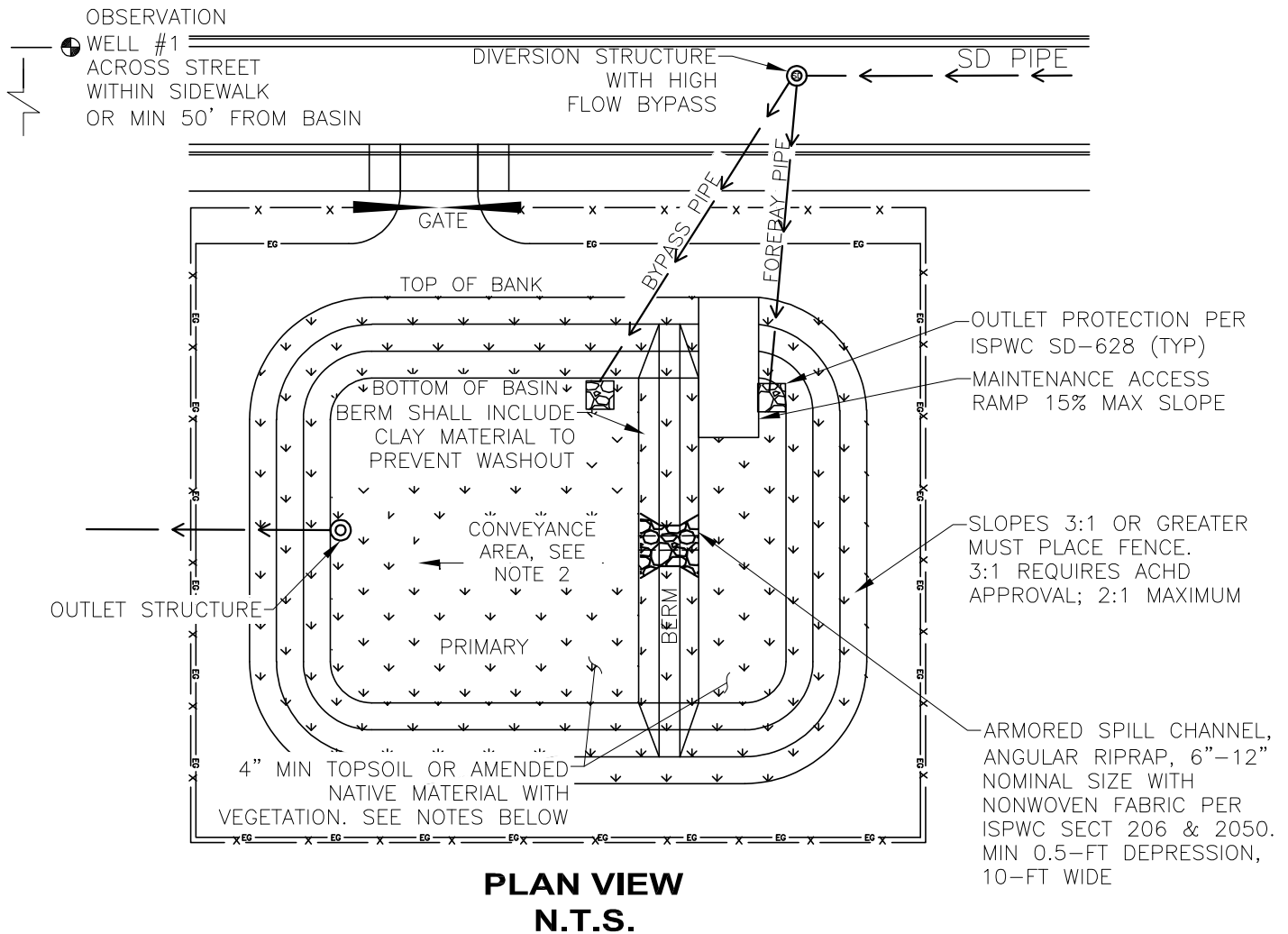

- NOTES:
1. SEE STORMWATER BASIN STANDARDS DETAIL 4, SHEET 2
 2. 2% MIN SLOPE TO OUTLET FOR CONVEYANCE AREAS

8202.20 BMP 12 Detention Basin with Underdrain (Pretreatment, Treatment & Storage)

Description

This BMP is approved for pretreatment, treatment and storage.

Filtration for this BMP consists of a sand bed with an under drain.

Design

Refer to Section 8202.17 for design requirements.

No less than eighteen (18) inches of design professional recommended amended topsoil which shall include 3% or greater organic matter content that will support vegetation germination and growth shall be placed throughout the basin.

The bottom of the facility (below topsoil) shall be at least one foot above the seasonal highwater table and bedrock as determined by the geotechnical investigation

The perforated under drain pipe shall be 6-inch minimum diameter with a minimum wall thickness of SDR-35. Refer to the ISPWC Section 601, Par 2.2A.

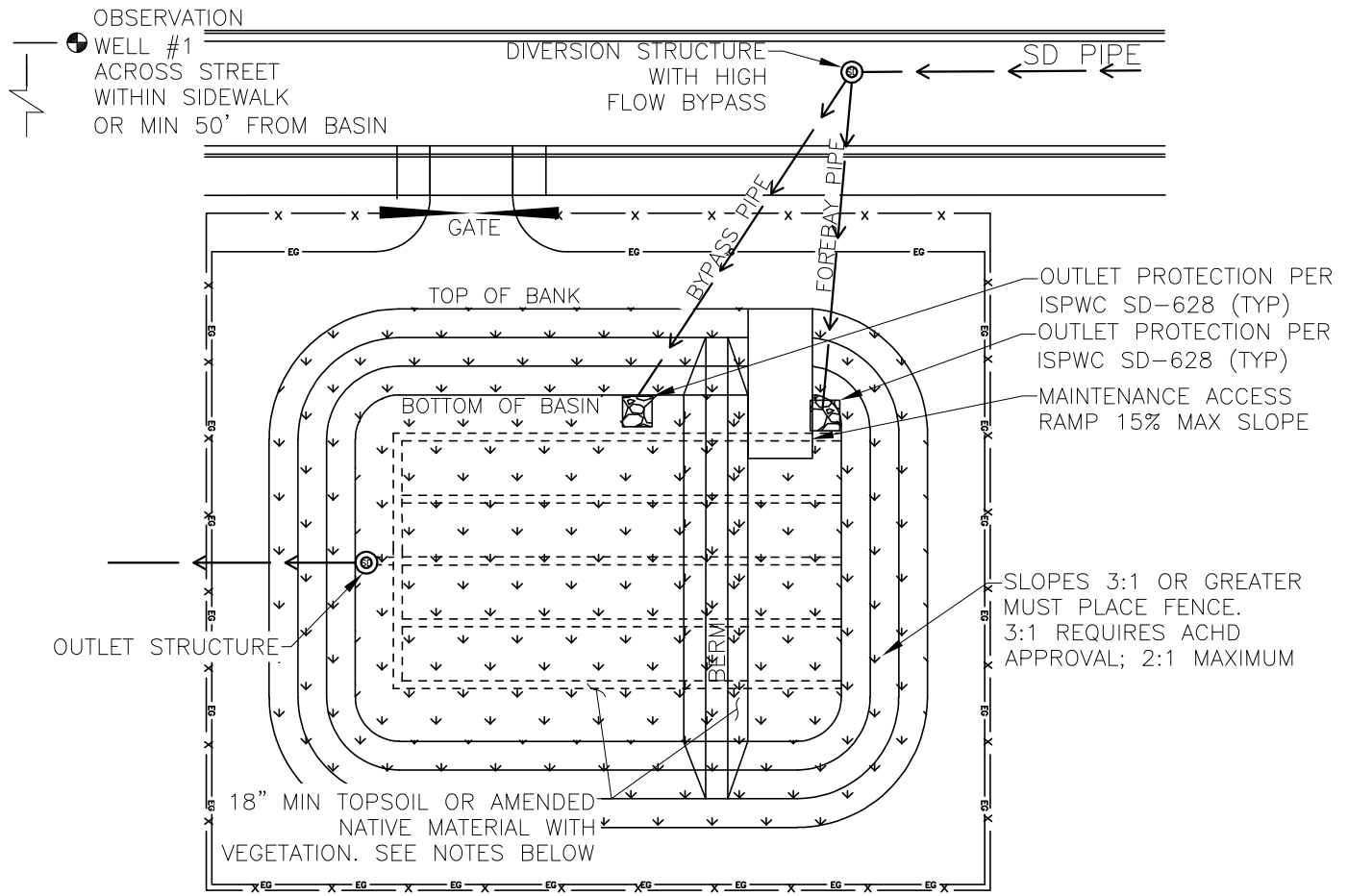

**PLAN
 N.T.S.**

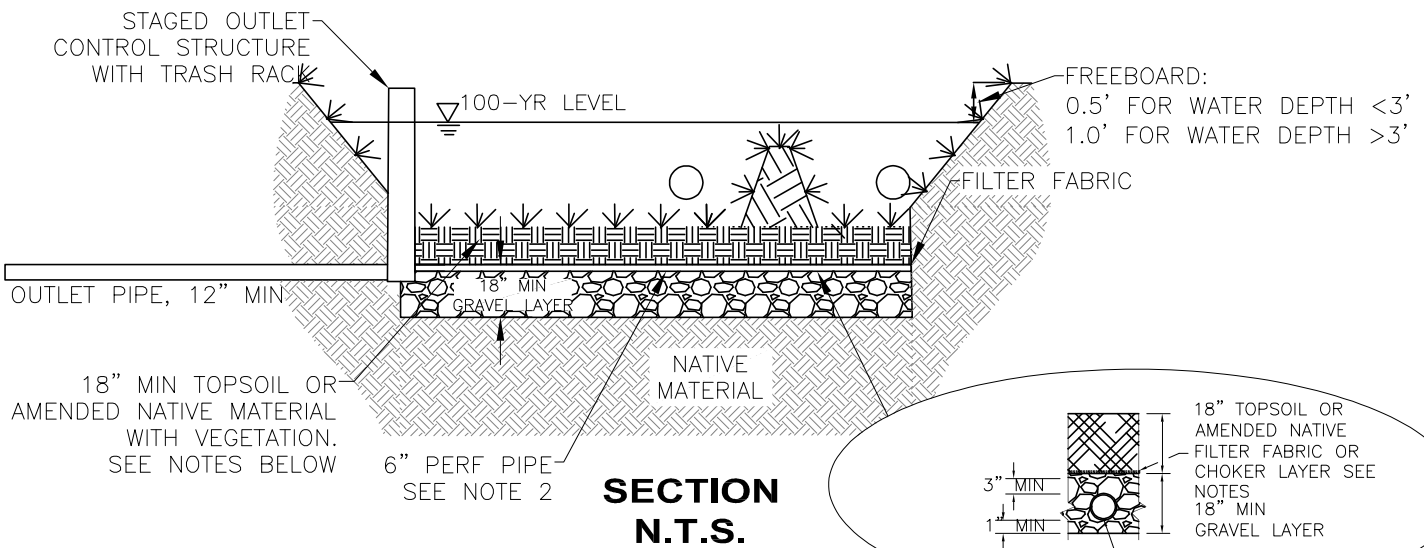

NOTES:

1. SEE STORMWATER BASIN STANDARDS DETAIL 4, SHEET 2
2. PERF PIPE MIN WALL THICKNESS SHALL BE SDR 35 PER ISPWC SECT 601, PART 2.2A
3. OPTIONAL CHOKER LAYER INSTEAD OF FILTER FABRIC UNDER TOPSOIL. USE ASTM #8 OPEN-GRADED FRACTURED AGGREGATE BEDDING COURSE 1 1/2" TO 2" THICK FOR CHOKER.

8202.21 BMP 13 Wet Retention or Detention Basin (Pretreatment, Treatment & Storage)

Description

This BMP is approved for pretreatment, treatment and storage.

A wet detention basin incorporates a permanent pool to detain a volume of water to allow for the settling of particles and associated pollutants.

Wet basins must be allowed by the lead land use agency and must be approved by ACHD prior to starting the design. Wet basins shall be incorporated as an amenity to the development. Water shall be aerated and/or have a source of fresh water circulating through the system to prevent the permanent pool of water from becoming stagnant. Aeration and/or circulation systems shall have an operations and maintenance plan and identify long-term maintenance responsibilities. The District SHALL NOT be responsible or liable for aeration and circulation systems.

Stormwater and irrigation may be combined at retention basins only. The CC&R's shall establish that the public drainage storage is secondary to the primary function of irrigation. The Home Owner's Association (HOA) shall have primary maintenance responsibility over the Primary Treatment/Storage Facility. ACHD shall perform heavy maintenance duties on the forebay only.

Design

Refer to Section 8202.17 for design requirements.

Wet basins shall be excavated to a minimum depth of 15-feet, adequate to intercept groundwater or shall be lined to retain water. Rigid impervious liners shall meet the specifications identified in Section 8202.17.

Wet basins shall be stabilized with vegetation to control dust and improve basin aesthetics. A landscaping plan for a basin and surrounding area should be prepared to indicate how aquatic and terrestrial areas will be stabilized, established, and maintained. Wetland plants shall be used in a basin design, along the aquatic bench and within shallow areas of the pool.

Wet basins shall be constructed with safety benches meeting the following criteria:

The perimeter of all deep permanent pool areas shall have a minimum 6-foot wide flat bench 1.5-feet below the normal pool water surface elevation. Basin slope between the top of the bank and bench shall not exceed 4:1.

A Tee post shall be identified on the plans and installed with the design operating water level clearly identified on the post.

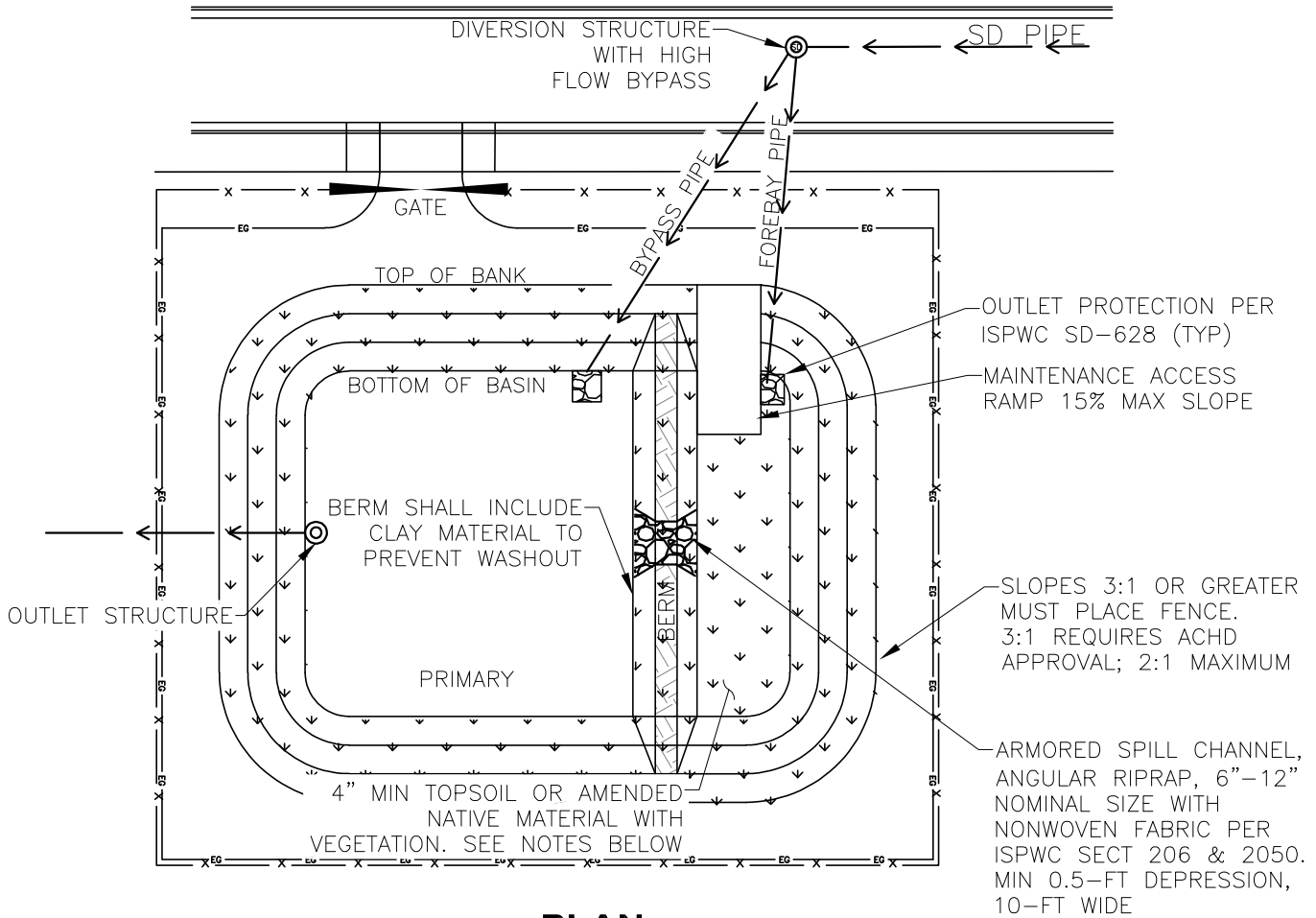

**PLAN
N.T.S.**

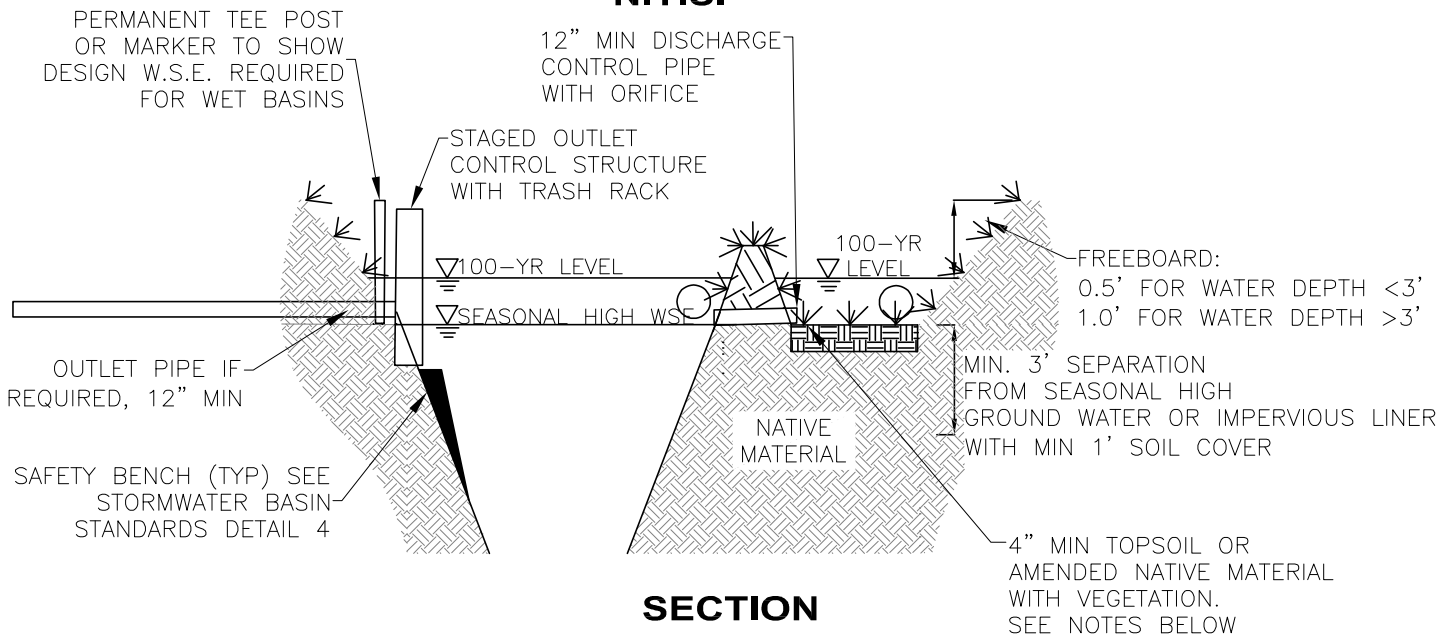

**SECTION
N.T.S.**

NOTES:

1. SEE STORMWATER BASIN STANDARDS DETAIL 4, SHEET 2
2. WET BASINS REQUIRE AN AERATION SYSTEM TO CIRCULATE WATER

8202.22 BMP 14 Constructed Wetland Basin (Treatment & Storage)

Description

This BMP is approved for treatment and storage.

A constructed wetland basin is a shallow basin, which requires a perennial base flow to permit the growth of vegetation and allow time for sedimentation, filtering, and biological uptake from stormwater.

Numerous design variations of constructed wetlands can be used to address unique individual site conditions and limitations, and may include shallow wetlands, extended detention shallow wetlands, basin/wetland systems, and pocket wetlands or wetland swales.

The wetland vegetation selected shall be presented in a plan prepared by a professional with demonstrated experience designing wetlands. The wetland planting plan must be submitted with the plan submittal and approved by ACHD prior to construction.

Design

Refer to Section 8202.17 for design requirements.

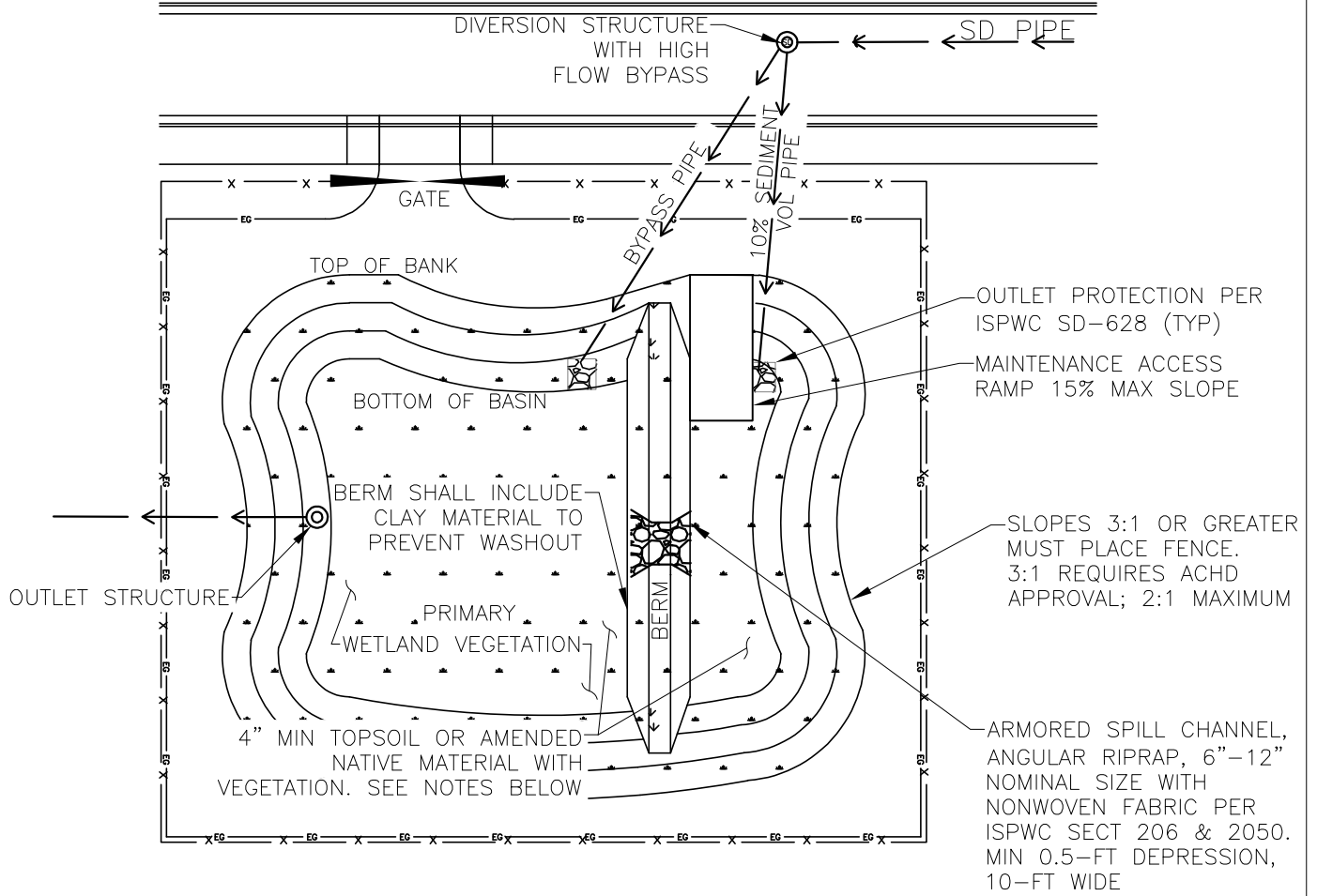

**PLAN
N.T.S.**

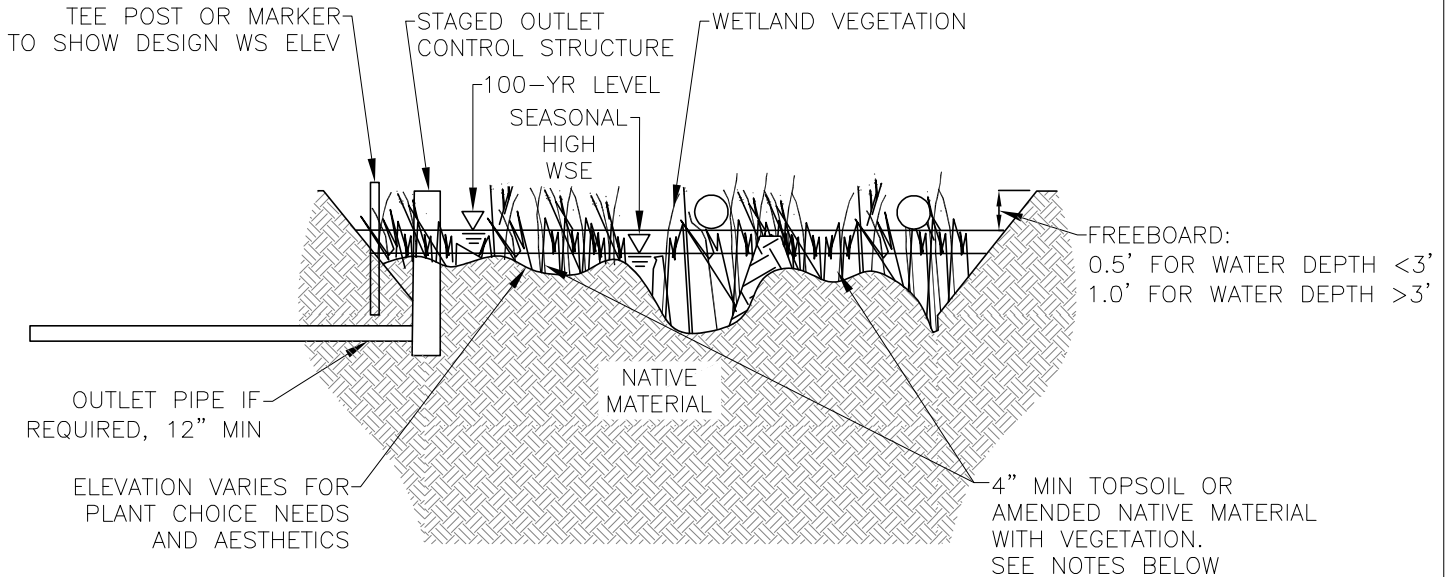

**SECTION
N.T.S.**

NOTES:

1. SEE STORMWATER BASIN STANDARDS DETAIL 4, SHEET 2

(BMPs 15-19 Reserved)

8202.23 BMP 20 Seepage Bed With Optional Chambers (Treatment & Storage)

Description

This BMP is approved for treatment and storage if preceded by another approved pretreatment BMP, except in foothill areas with slopes greater than 15%.

A seepage bed stores stormwater runoff in a trench backfilled with uniformly sized drain rock above a sand filter and infiltrates the water into the ground.

Flows shall be pretreated upstream using approved pretreatment BMPs. The system may also include underground storage chambers for additional storage. When chambers are used, the manufacturer's product technical data and letter of project review and approval and specifications for product installation requirements shall be submitted.

Design

Seepage beds and underground stormwater chambers shall be sized to store the 100-year design storm of one-hour duration accounting for infiltration, unless it can be safely conveyed or detained in the right-of-way or stormwater easement without flooding the sidewalk and impacting private property. In this case, the facility can be sized for the one-hour, 25-year design storm. Facilities must infiltrate 90% of the design storm in 48-hours through the area of the sand filter. The calculated volume shall be increased by 25% to account for sediment. When the seepage bed is located within a common lot, additional sediment storage shall not be required.

Seepage beds located within the right-of-way may extend no greater than five feet out from face of curb and shall not encroach on a private lot. Seepage beds shall be no greater than ten (10) feet in depth to the bottom of the rock.

Seepage beds shall have a minimum cover of 1.5 feet. If placed in the roadway (Capital Projects only) or under the sidewalk, minimum cover is 1 foot below the pavement subgrade.

A stone aggregate of clean, washed drain rock, 1.5 to 2 inches in diameter should be used for storage. Crushed aggregates to interlock are required for storage chambers. Follow Manufacturer's recommendations. Other materials may be used to create voids per the table below. Void volumes for the specific materials used must be lab verified and clean with less than 2 percent passing a 200 sieve.

Void Volume of Typical Materials	
Material	Void Volume %
2" Max Blasted Rock	30
(1-½" to 2") Uniform Size Gravel	40
¾" Uniform Size Crushed Chips	40
Crushed Glass	30

Crushed aggregates shall have a minimum 50% crushed or fractured face (at least on one side) and meet the following gradation:

Crushed Aggregate	
Sieve Size	Percent Passing
3 inch	100%
¾ inch	25-60%
⅜ inch	0-4%
No. 200	0-2%

The Design Professional may determine void volumes for other materials by laboratory analysis and submit them to the District for review.

The 18-inch perforated pipe shall have ⅜-inch perforations within the corrugation valleys per the schedule in this standard detail.

Following are the requirements for drainage geotextiles. Nonwoven or monofilament woven geotextiles are required. Slit film or slit tape geotextiles are not approved for drainage applications.

Non-Woven Filter Fabric

Property	Test Method	English
Tensile Strength (Grab)	ASTM D-4632	120 lbs
Elongation	ASTM D-4632	50%
Puncture	ASTM D-4833	65 lbs
Trapezoidal Tear Strength	ASTM D-4533	50 lbs
UV Resistance	ASTM D-4355	70%
Apparent Opening Size (AOS)	ASTM D-4751	70 US Std. Sieve
Permittivity	ASTM D-4491	1.50 sec-1
Water Flow Rate	ASTM D-4491	120 gpm/ft ²

Woven Fabric

Property	Test Method	English
Tensile Strength (Grab)	ASTM D-4632	Min 250 lbs
Puncture Strength or CBR Puncture	ASTM D-4833 or ASTM D-6241	Min 125 lbs or Min 950 lbs
UV Resistance	ASTM D-4355	Min 80%
Apparent Opening Size (AOS)	ASTM D-4751	70 US Std. Sieve
Water Flow Rate	ASTM D-4491	Min 18 gpm/ft ²
Percent Open Area	CW-02215	Min 4%

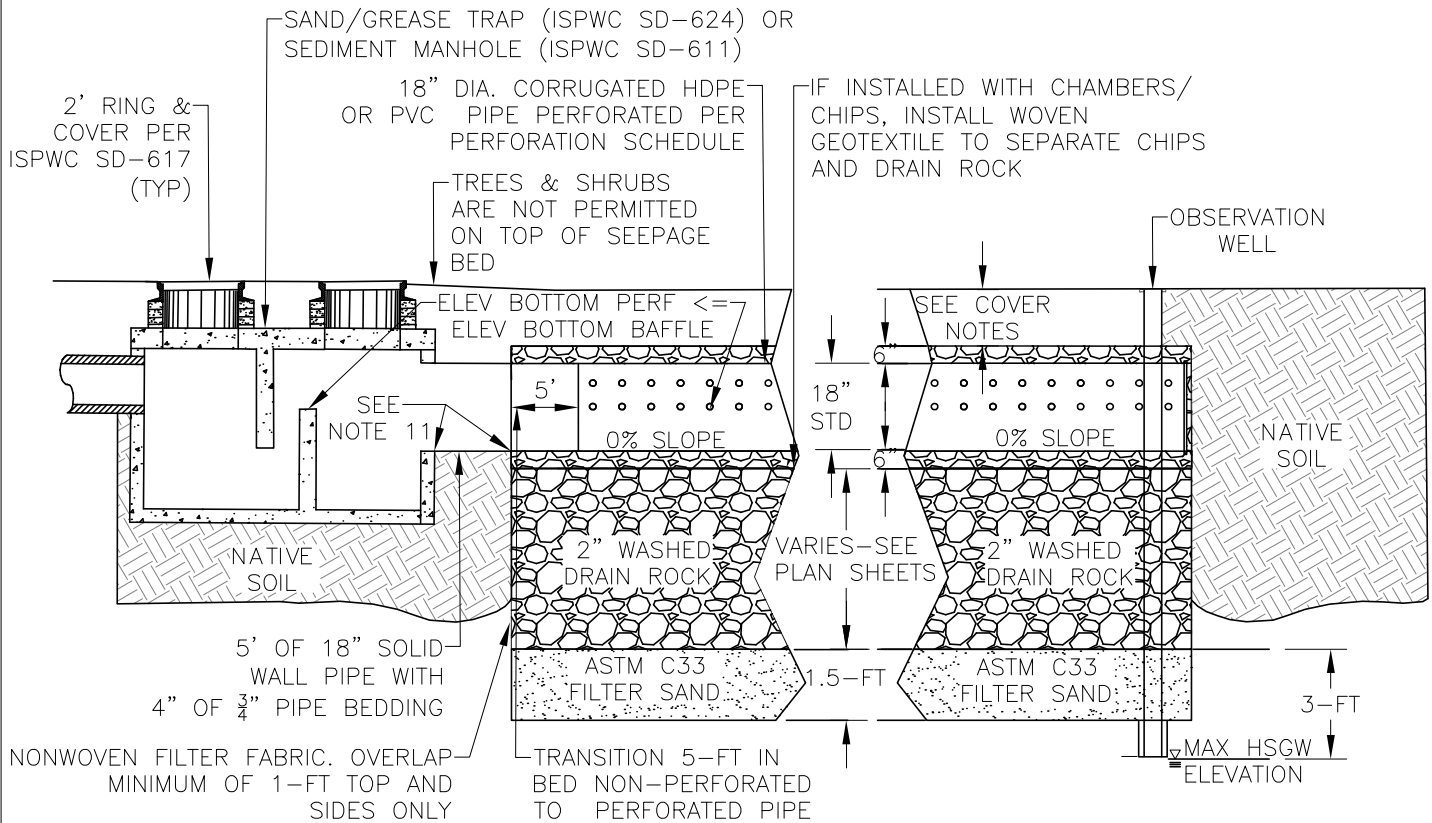

**SECTION
N.T.S.**

NOTES:

1. BMP 1-4 OR VEGETATED PRETREATMENT IS REQUIRED.
2. CONTACT DESIGN PROFESSIONAL FOR SEEPAGE BED REDESIGN IF GROUNDWATER IS ENCOUNTERED ABOVE MAX HSGW ELEVATION
3. ALL VAULTS, MANHOLES, & SAND AND GREASE TRAPS SHALL BE HS25 OR GREATER LOAD RATED
4. SEEPAGE BED SHALL BE SHOWN ON BOTH PLAN AND PROFILE VIEWS
5. OPTIONAL CHAMBERS PER MANUFACTURERS SPECIFICATIONS
6. ALL GEOTEXTILE SEAMS SHALL OVERLAP 1 FOOT MINIMUM
7. EL. IN \geq EL. BOTTOM PERFORATIONS IN 18" PERF PIPE
8. MAXIMUM BED LENGTH IS 400-FT BETWEEN MANHOLES
9. BED WIDTH SHALL REMAIN CONSTANT
10. WATERTIGHT CONNECTION REQUIRED
11. HIGH FLOW BYPASS PIPE ONLY NEEDED IF Q100 VELOCITY THROUGH STRUCTURE $>$ 0.5 FPS

COVER NOTES:

FOR SEEPAGE BEDS OUTSIDE PUBLIC RIGHT-OF-WAY:

1. A MINIMUM 1.5-FT COVER FROM TOP OF BED TO FINISH GRADE IS REQUIRED

FOR SEEPAGE BEDS IN PUBLIC RIGHT-OF-WAY:

1. A MINIMUM 1.0-FT COVER FROM TOP OF BED TO PAVEMENT SUBGRADE IS REQUIRED
 --BACKFILL OVER BED TO SUBGRADE WITH 6"-8" MINUS PITRUN
 --WOVEN GEOTEXTILE FABRIC REQUIRED OVER TOP OF BED
 --TOP OF BED UNDER SIDEWALK SHALL BE MIN 1.0-FT BELOW PAVEMENT SUBGRADE
2. IF $<$ 1.0-FT COVER FROM TOP OF BED TO SUBGRADE, ANGULAR 3/4" TO 2" ROCK IS REQUIRED WITH MINIMUM 50% SINGLE FRACTURED FACE IN PLACE OF 2" DRAIN ROCK.
3. FULL ROADWAY SECTION IS REQUIRED OVER SEEPAGE BEDS. SEEPAGE BEDS SHALL NOT EXTEND ABOVE SUBGRADE
4. THE DESIGN PROFESSIONAL IS SOLELY RESPONSIBLE FOR ASSESSING THE BEARING RESISTANCE OF THE SUBGRADE SOILS AND DETERMINING THE DEPTH OF FOUNDATION STONE

SEE BMP 20 SHEET 2 OF 3 FOR ADDITIONAL NOTES

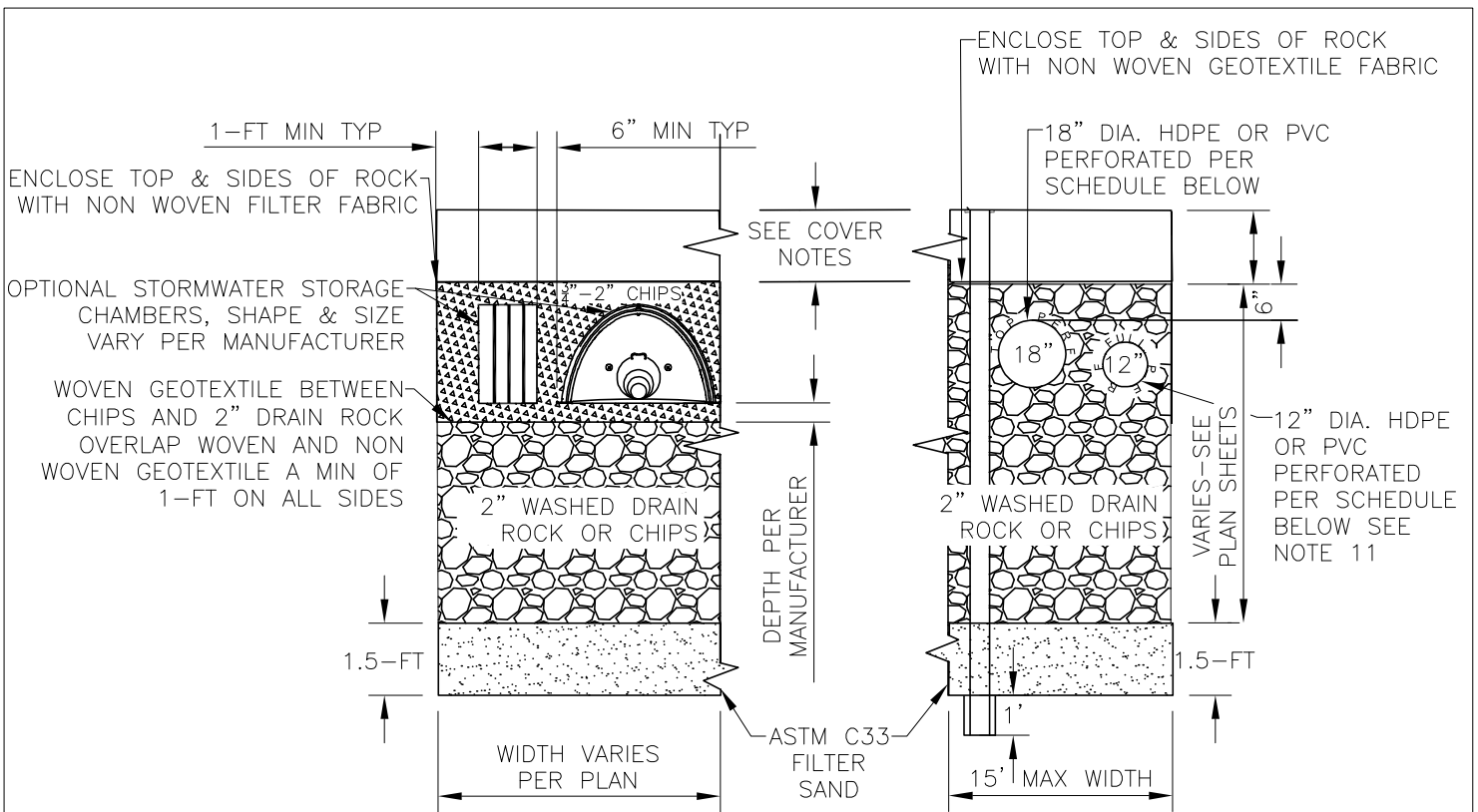

OPTIONAL CHAMBER SECTION
N.T.S.

STANDARD SECTION A-A
N.T.S.

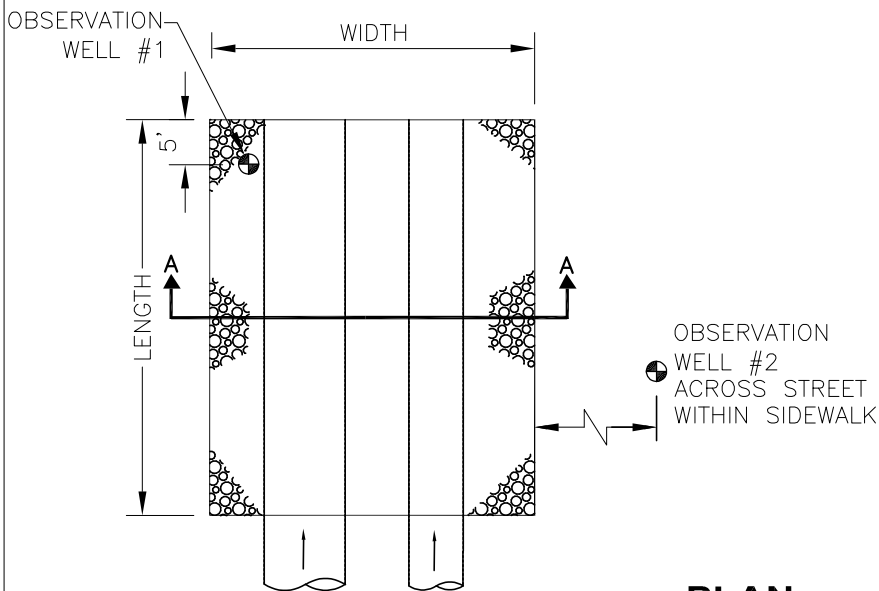

OBSERVATION WELLS: 2 REQUIRED PER BED

PLAN
N.T.S.

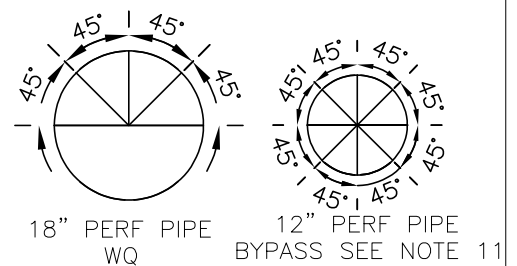

PERFORATION SCHEDULE
3/8" PERFORATIONS IN VALLEYS OF CORRUGATED PIPE. 5 EA ON 18", 8 EA ON 12"

REQUIREMENTS FOR FACILITIES IN RIGHT-OF-WAY

1. BED IS LIMITED TO AREA WITHIN 5-FT OF CURB FACE UNDER ROADWAY;
2. NO GREATER THAN 10-FOET IN DEPTH TO THE BOTTOM OF THE ROCK;
3. MAY NOT EXTEND OUTSIDE OF THE RIGHT-OF-WAY (MAY NOT ENCROACH ON PRIVATE LOT IN AN EASEMENT);

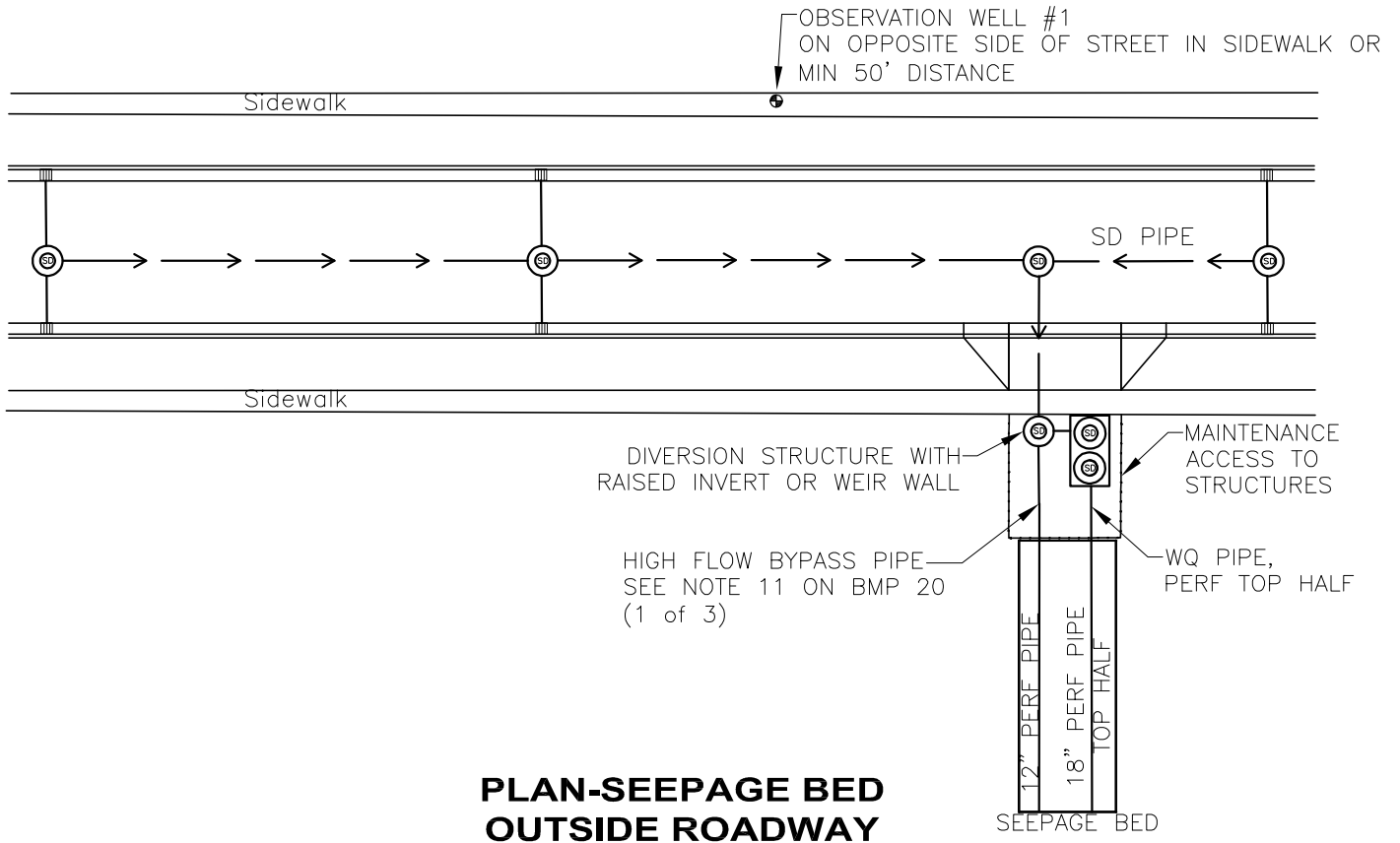

**PLAN-SEEPAGE BED
OUTSIDE ROADWAY
N.T.S.**

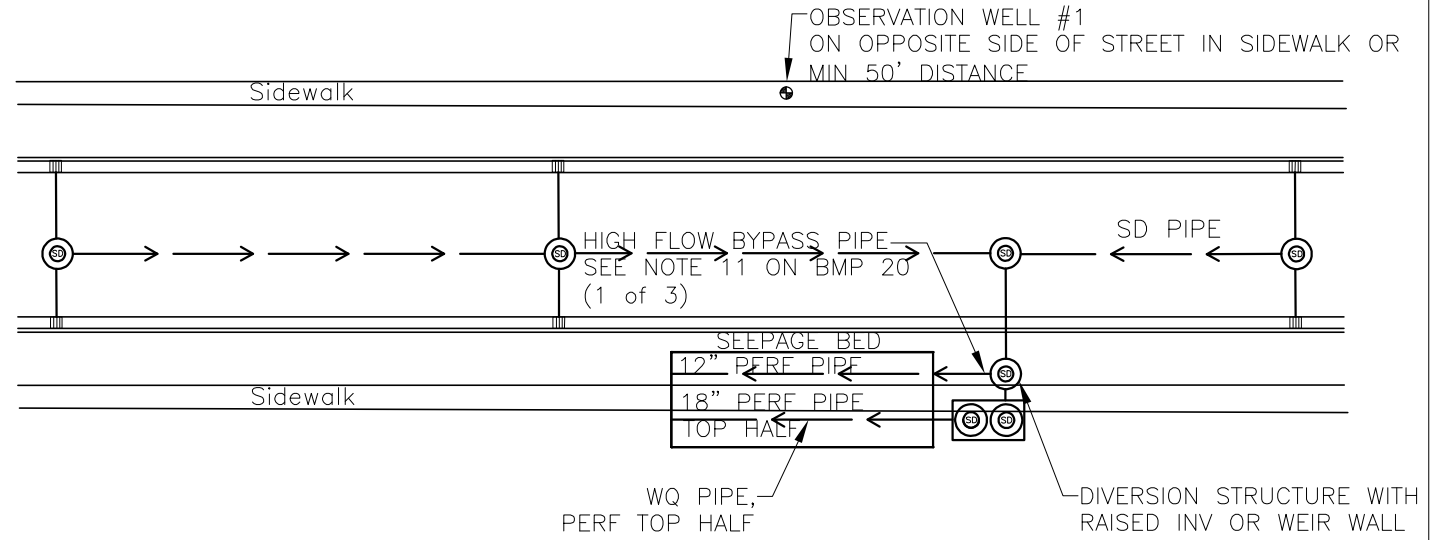

**PLAN-SEEPAGE BED
UNDER SIDEWALK
N.T.S.**

8202.24 BMP 21 Vertical Sand Filter

Description

Vertical sand filters are approved for treatment and storage only in areas where 3-foot separation to high groundwater is not possible. Vertical sand filters are only allowed within subdivision common lots. Use of this BMP requires written approval from ACHD. Flows shall be pretreated upstream using approved pretreatment BMPs.

Vertical sand filters capture and temporarily store stormwater runoff and pass it through a filter bed of sand. The first chamber is lined and backfilled with uniformly sized drain rock that stores stormwater until sufficient head is created to force the water through the sand filter to the second chamber.

Design

The first chamber of the vertical sand filter shall be sized to hold the 2-year 1-hour event. The sand filter shall be a minimum of 1.5 feet thick. Water moves through the sand filter to a second chamber which shall be sized to store the entire 100-year design storm of one-hour duration. High flow bypass is always required. Both chambers shall be backfilled with stone aggregate of clean, washed drain rock, 1.5 to 2 inches in diameter.

A minimum horizontal separation of 10 feet should be used between vertical sand filters and a structural foundation. The geotechnical investigation and report shall include an evaluation of the potential for groundwater mounding to determine if a larger separation distance is needed. When groundwater mounding poses a risk to structures, use of BMPs that are more distributed (smaller footprint area per unit) or are more linear in nature should be used to help reduce mounding potential.

The liner shall be thirty mil (minimum) PVC Geomembrane that meets the specifications in Section 8202.17. A clay liner is not allowed. Penetration of the liner for any utility services (water, sewer, irrigation, groundwater monitoring) is not allowed.

Cover shall be a minimum of 1.5 feet over the entire vertical sand filter. If placed in the roadway or under sidewalk, minimum cover is 1-foot below the pavement subgrade.

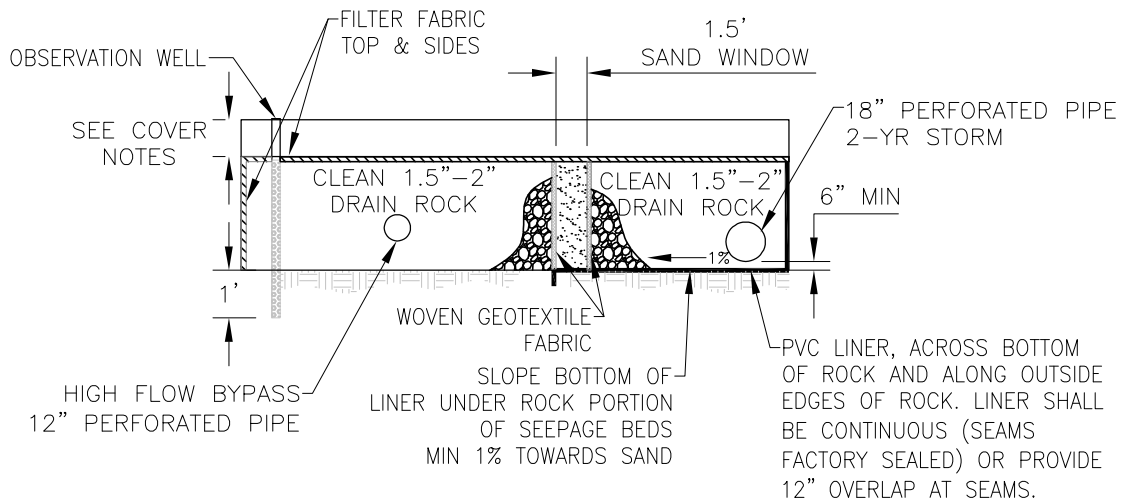
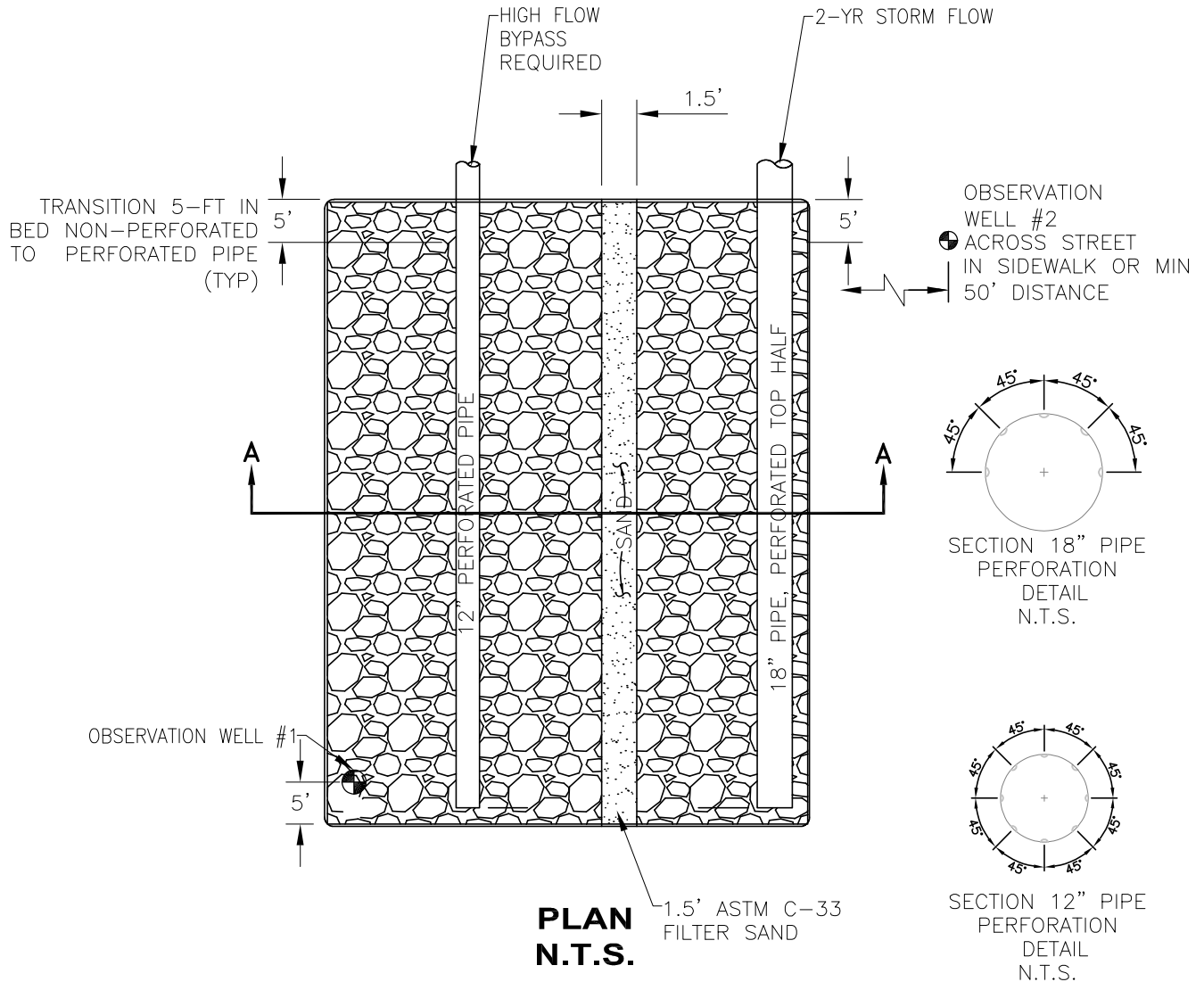

NOTES:

1. THIS BMP MUST BE APPROVED FOR USE BY ACHD AND IS ONLY ALLOWED WHERE 3-FT SEPARATION TO HSGW IS NOT POSSIBLE. BMP SHALL ONLY BE ALLOWED IN COMMON AREAS.
2. BMP 1-4 OR VEGETATED PRETREATMENT IS REQUIRED.
3. CONTACT DESIGN PROFESSIONAL FOR VERTICAL SAND FILTER REDESIGN IF GROUNDWATER IS ENCOUNTERED ABOVE MAX HSGW ELEVATION
4. ALL VAULTS, MANHOLES, & SAND AND GREASE TRAPS SHALL BE HS25 OR GREATER LOAD RATED
5. VERTICAL SAND FILTER SHALL BE SHOWN ON BOTH PLAN AND PROFILE VIEWS
6. OPTIONAL CHAMBERS PER MANUFACTURERS SPECIFICATIONS
7. ALL GEOTEXTILE SEAMS SHALL OVERLAP 1 FOOT MINIMUM
8. MAXIMUM BED LENGTH IS 400-FT BETWEEN MANHOLES
9. BED WIDTH SHALL REMAIN CONSTANT

COVER NOTES:

THIS BMP IS ALLOWED IN THE RIGHT-OF-WAY ONLY FOR CAPITAL AND MAINTENANCE PROJECTS.

FOR VERTICAL SAND FILTERS IN PUBLIC RIGHT-OF-WAY:

10. A MINIMUM 1.0-FT COVER FROM TOP OF BED TO PAVEMENT SUBGRADE IS REQUIRED
 - BACKFILL OVER BED TO SUBGRADE WITH 6"-8" MINUS PITRUN
 - WOVEN GEOTEXTILE FABRIC REQUIRED OVER TOP OF BED
 - TOP OF BED UNDER SIDEWALK SHALL BE MIN 1.0-FT BELOW PAVEMENT SUBGRADE
11. IF < 1.0-FT COVER FROM TOP OF BED TO SUBGRADE, ANGULAR $\frac{3}{4}$ " TO 2" ROCK IS REQUIRED WITH MINIMUM 50% SINGLE FRACTURED FACE IN PLACE OF 2" DRAIN ROCK.
12. FULL ROADWAY SECTION IS REQUIRED OVER VERTICAL SAND FILTERS. VERTICAL SAND FILTERS SHALL NOT EXTEND ABOVE SUBGRADE
13. THE DESIGN PROFESSIONAL IS SOLELY RESPONSIBLE FOR ASSESSING THE BEARING RESISTANCE OF THE SUBGRADE SOILS AND DETERMINING THE DEPTH OF FOUNDATION STONE

FOR VERTICAL SAND FILTERS OUTSIDE PUBLIC RIGHT-OF-WAY:

1. A MINIMUM 1.5-FT COVER FROM TOP OF BED TO FINISH GRADE IS REQUIRED

8202.25 BMP 22 Underground Sand Filter Vault (Pretreatment, Treatment)

Description

This is approved as a pretreatment BMP if the sand filter is sized to treat the runoff reduction volume. If the sand filter is sized to treat the entire 25-year design storm then this BMP can provide primary treatment. Storage facilities or an approved discharge are required for the design storm.

The Underground Sand Filter Vault consists of a chamber to hold sediment, a filter sand surface for capture of pollutants over the top of perforated under drain pipes in a gravel bed.

Design

The perforated under drain pipe shall be a minimum 6-inch diameter. A precast vault, 1500 Gallon Sand/Grease Trap or similar, with two manhole accesses shall be used.

Due to the limited infiltration rate through the filter sand, sand filters can only accommodate a small peak discharge as shown below without additional storage.

<u>Unit</u>	<u>Max Q</u>
1500 Gallon Tank w/Sand Bed, Approx. inside dimension 5'x7'x7'	0.39 cfs

Manufactured additives can be added to the sand media for additional treatment of pollutants of concern like phosphorus.

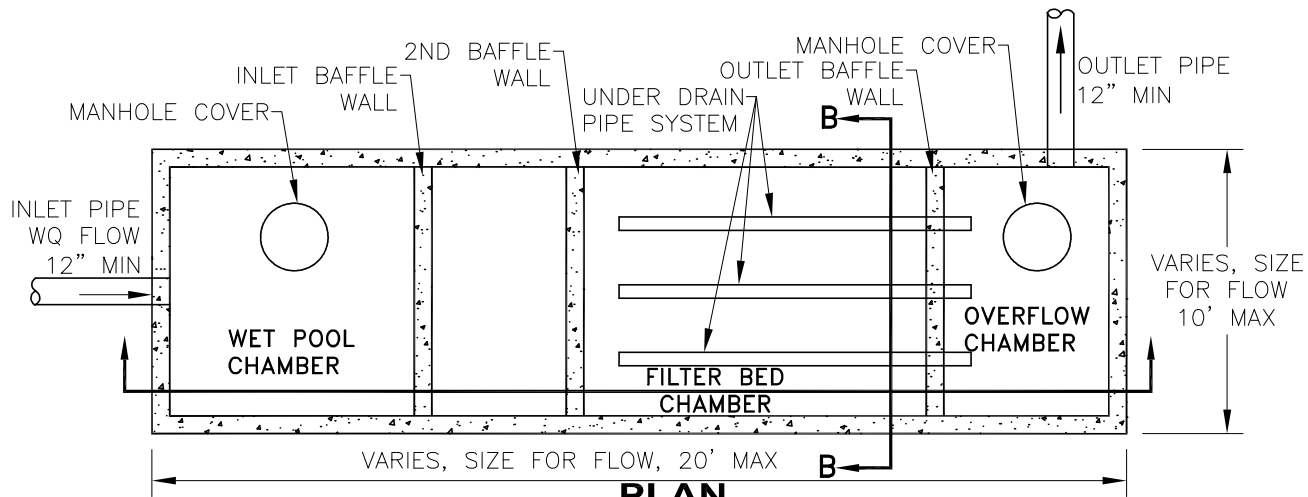

**PLAN
N.T.S.**

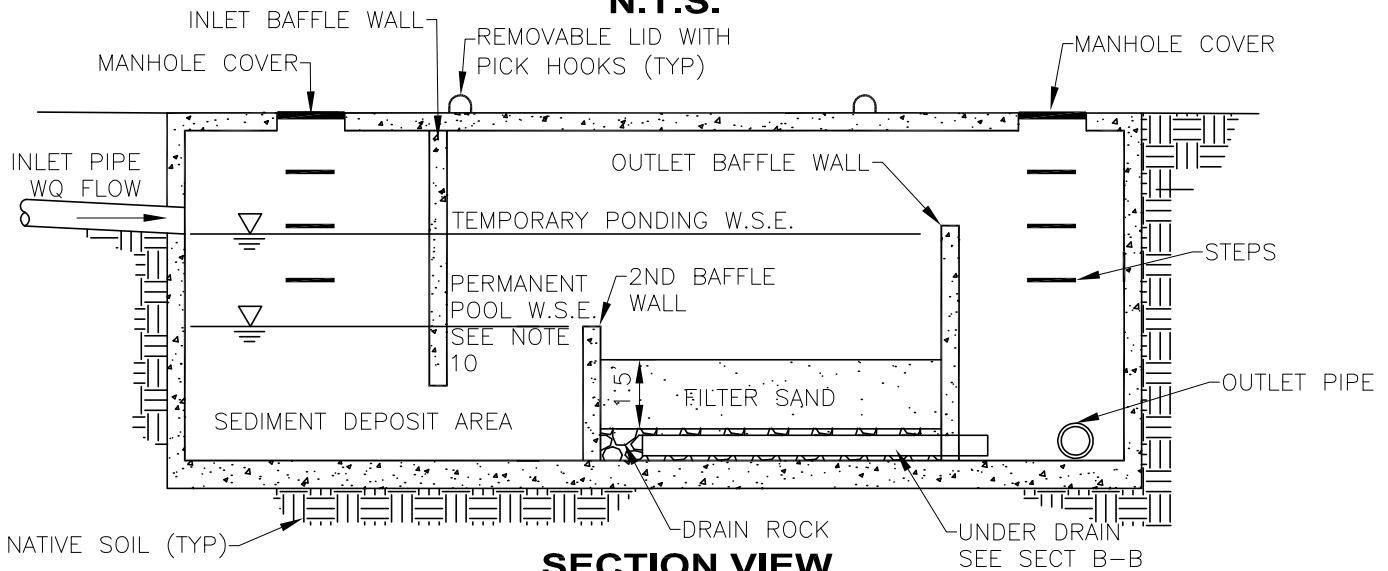

**SECTION VIEW
N.T.S.**

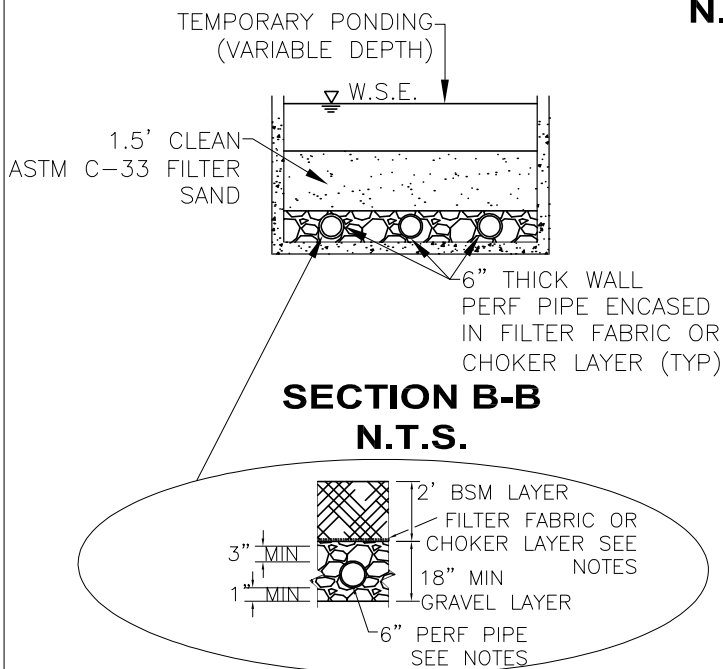

**SECTION B-B
N.T.S.**

NOTES:

1. THIS BMP FOR USE OUTSIDE OF THE ROADWAY PRISM
2. ALL REINFORCING STEEL SHALL BE GRADE 60
3. CAST-IN-PLACE BOX DESIGN MUST BE APPROVED BY ACHD PRIOR TO CONSTRUCTION
4. HEIGHT OF OUTLET Baffle WALL AND LENGTH OF INLET Baffle WALL DETERMINED BY TANK CAPACITY AND FLOW RATE
5. BEFORE THESE BOXES ARE USED THE APPLICATION MUST BE APPROVED BY ACHD
6. MANHOLE FRAME, COLLAR AND COVER SHALL BE PER SD-616 AND SD-617
7. PROVIDE STEPS WHEN THE DISTANCE FROM TOP OF MANHOLE FRAME TO TOP OF BOX EXCEEDS 2-FT
8. PERF PIPE MIN WALL THICKNESS SHALL BE SDR 35 PER ISPWC SECT 601, PART 2.2A
9. PERMANENT POOL W.S.E. IS EQUAL TO HEIGHT OF 2ND Baffle WALL
10. OPTIONAL CHOKER LAYER INSTEAD OF FILTER FABRIC UNDER SAND. SEE BMP 12 FOR CHOKER SPEC.

8202.26 REQUIREMENTS FOR BIORETENTION FACILITIES

8202.26.1 Description

A bioretention facility is an infiltration device consisting of an excavated area that is back-filled with a Bioretention Soil Media (BSM) and planted with vegetation. Bioretention facilities include Swales (BMP 30), Planters (BMP 31), and Curb Extensions (BMP 32).

8202.26.2 Siting

Sloped areas immediately adjacent to the bioretention facility shall be less than 2% but greater than 0.5% for pavement and greater than 1% for vegetated areas to ensure positive flow towards the device.

The area draining to the bioretention facility shall not exceed 2 acres. The drainage area shall not contain significant sources of soil erosion.

Requirements in the ACHD Policy Manual for infiltration facilities shall apply.

If an impermeable liner and an under drain are used, no setback is needed from buildings. Otherwise, the 10-foot setback shall apply. Where an impermeable liner is included between facility and adjacent infrastructure (street, parking lot), a 30 MIL HDPE or PVC material shall be used. No setbacks are required for lined flow-through planters where the height above finished grade is 30 inches or less.

8202.26.3 General Design Criteria

All AASHTO Roadside Design Guide Requirements shall be met when developing bioretention facilities.

A parking step-out zone of 24" measured from face of curb shall be provided for bioretention facilities adjacent to parking lanes.

Pedestrian crossings of continuous bioretention facilities adjacent to curb are required as below.

- One 6' concrete crossing between each street tree and 35 foot maximum spacing in high-volume pedestrian areas.
- One 6' crossing every other tree and 70 foot maximum spacing in other areas consistent with surrounding area (paved, grass, or mulched).

Access is required to all bioretention areas for maintenance.

Inlets shall include a rock pad, concrete or other erosion protection device in the channel entrance to dissipate energy. The flow entrance shall drop 2 to 3 inches from curb line and provide an area for settling and periodic removal of sediment.

Pretreatment shall be provided and may include shallow catch basins, a pea gravel trench, stone splash pad, or filter strip.

8202.26.4 Flow Regulation

The flow at the inlet to the bioretention device shall be controlled to prevent erosion and to achieve uniform distribution across the surface of the soil planting bed.

Provide aggregate (6" depth, 3"-6" rounded), washed cobble or concrete splash pads at inlets.

An overflow structure is required for on-line systems without an overflow bypass and shall connect to approved discharge point or another downstream bioretention area. Overflow structures shall be sized to safely convey larger storm events.

When a standpipe with a trash guard is used to regulate the maximum ponding depth, the invert elevation of the overflow structure shall be equal to the maximum ponding depth of the bioretention device. Vertical stand pipes can be connected to under-drain systems, horizontal drainage pipes, or armored overflow channels installed at the designed maximum ponding elevations.

Maximum surface pool drawdown time shall be 48 hours.

8202.26.5 Storage Layer

A 6-inch thick filter layer of ¾" (No. 4) open-graded aggregate and a 12-inch gravel drainage layer (No. 57) shall be used for subsoil infiltration rates less than 0.5 inches/hour. The swale shall be sized to capture and store 100% of the design volume within the filter media (BSM, sand, and underdrain stone). The bottom of the gravel drainage layer shall be separated at least one foot vertically from the bedrock layer or seasonal high water table, measured from the bottom of the aggregate.

Where an aggregate layer is used and trees are specified, replace aggregate with increased BSM depth in tree planting locations.

8202.26.6 Bioretention Soil Media (BSM)

The Bioretention Soil Media (BSM) is specified in Appendix F. All bioretention facilities shall include a minimum of 24 inches of Bioretention Soil Mix (BSM). The bottom of the facility (below BSM) shall be at least one foot above the seasonal high water table and bedrock as determined by the geotechnical investigation. Deeper BSM profiles may be required in areas with high groundwater, high infiltration rates or underdrains. BSM depth should also be adjusted to accommodate expected rooting depths of vegetation.

The Contractor shall not place BSM until the Inspector has reviewed and confirmed the following:

- Soil mix delivery ticket(s). Delivery tickets shall show that the full delivered amount of soil matches the product type, volume and Manufacturer named in the submittals.

- Visual match with submitted samples. Delivered product will be compared to the submitted sample, to verify that it matches the submitted sample.
- The Inspector may inspect any loads of soil and stop placement if it is determined that the delivered soil does not appear to match the submittals; and require sampling and testing of the delivered soil, before authorizing soil placement. All testing costs shall be the responsibility of the Contractor.

BSM shall be placed as described in Appendix F.

8202.26.7 Vegetation/Mulch

The entire bioretention facility area shall be planted with vegetation. Native plant species are preferred over non-native species. Salt resistant vegetation should be used in locations with probable adjacent salt application.

Prevent erosive conditions during germination and establishment of vegetation. The use of temporary or permanent stabilization fabrics or materials is required.

Provide irrigation for plant establishment (2-3 years), and supplemental irrigation during periods of prolonged drought. Provide a separate zone for the connection to water supply.

Mulch must be aged, stabilized, non-floating mulch, such as a specified compost mulch or shredded hardwood bark mulch.

Tree dams, using tree mounds, can be used and should be no higher than 6-9 inches above the bottom (invert) of the channel.

Do not locate plants at inlets. Consider mature growth to determine planting layout and avoid future blockage of inlets by plants. Trees located on slopes should be 5' minimum from inlets to avoid erosion of the soil at the root ball.

8202.27 BMP 30 Bioretention Swale (Treatment & Storage)

Description

This BMP is approved for pretreatment, or treatment and storage. Bioretention swales are a graded and engineered landscape feature appearing as a linear, shallow, open channel with trapezoidal or parabolic shape. Bioretention swales act as a filter medium removing pollutants and allowing stormwater infiltration. Bioretention swales can be used on arterials and collectors, in subdivision common areas including medians; and as retrofits to provide pollutant reduction on existing development that is currently untreated by any BMP or is inadequately treated by an existing BMP. It can also include conversion, enhancements or restoration of older BMPs to improve their performance.

Design

Bioretention swales must meet the requirements of Section 7200 for lots one-acre and larger or be located on commercial, collector or arterial roadways behind vertical curb, or in subdivision common lots or medians. Use of this BMP requires written approval from ACHD.

When a swale is intended to be used for infiltration, the site evaluation requirements for infiltration facilities shall apply.

Infiltration swales shall include a minimum of 24 inches of Bioretention Soil Mix (BSM) on the entire bottom of the swale.

A 2' minimum flat bottom width shall be required for a bioretention swale. Side slopes shall be 4:1 or flatter.

Maximum longitudinal bottom slope shall be 6 percent. Longitudinal slope shall be 2 percent maximum between berms. Provide check dams if needed to increase detention time and infiltration capability on sloped sites and to reduce flow velocity and potential erosion.

The bioretention facilities should be heavily vegetated with grasses, and may also be landscaped to enhance their function and appearance. Swales can be planted with turf grass, native grasses, decorative herbaceous cover, or trees on the dams.

If turf grass is used, only washed sod or sod grown on sandy soils shall be allowed on the areas designed to infiltrate and the sides of the facility. Barriers shall be used to protect the infiltration areas from other sodded areas until the vegetation is established. Minimum vegetation height of 4 inches is recommended.

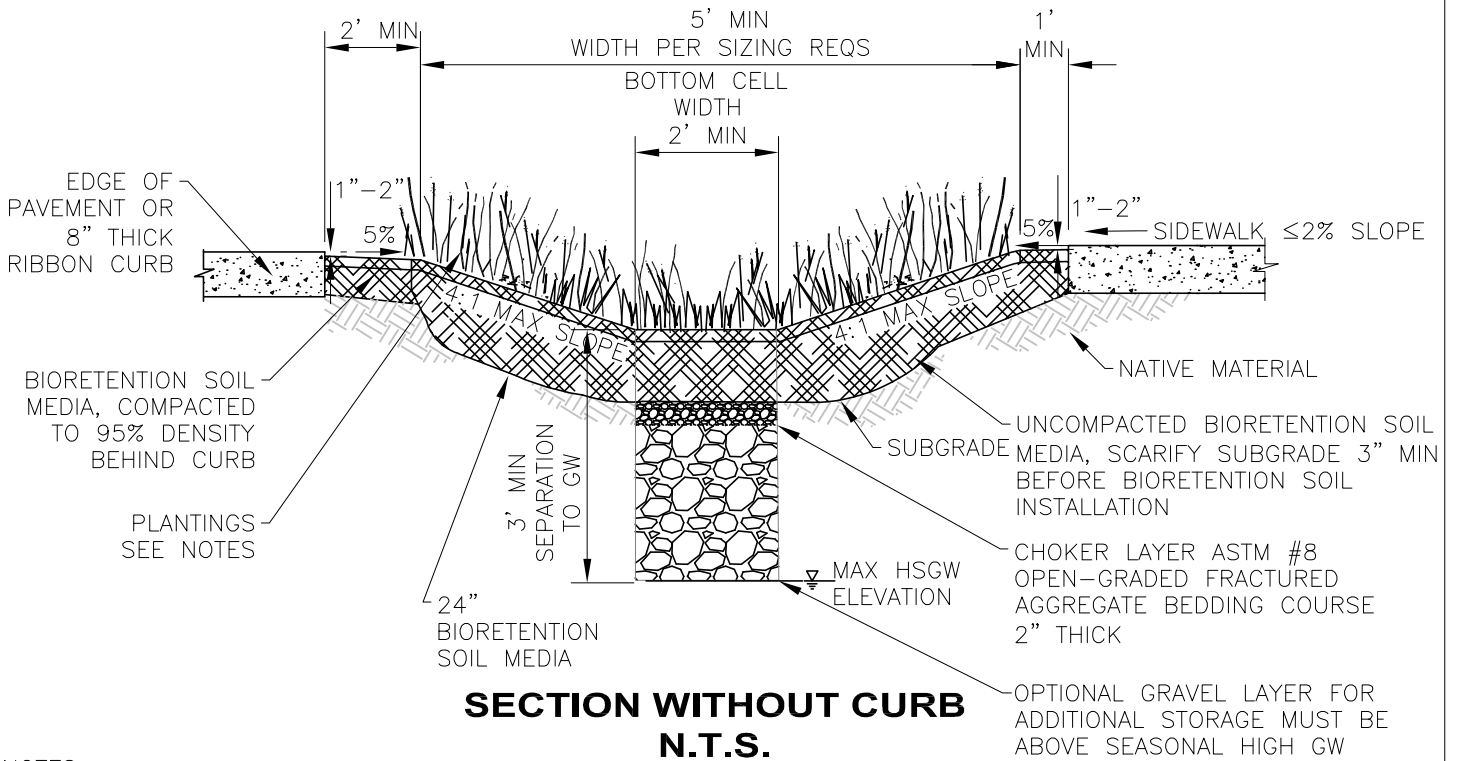
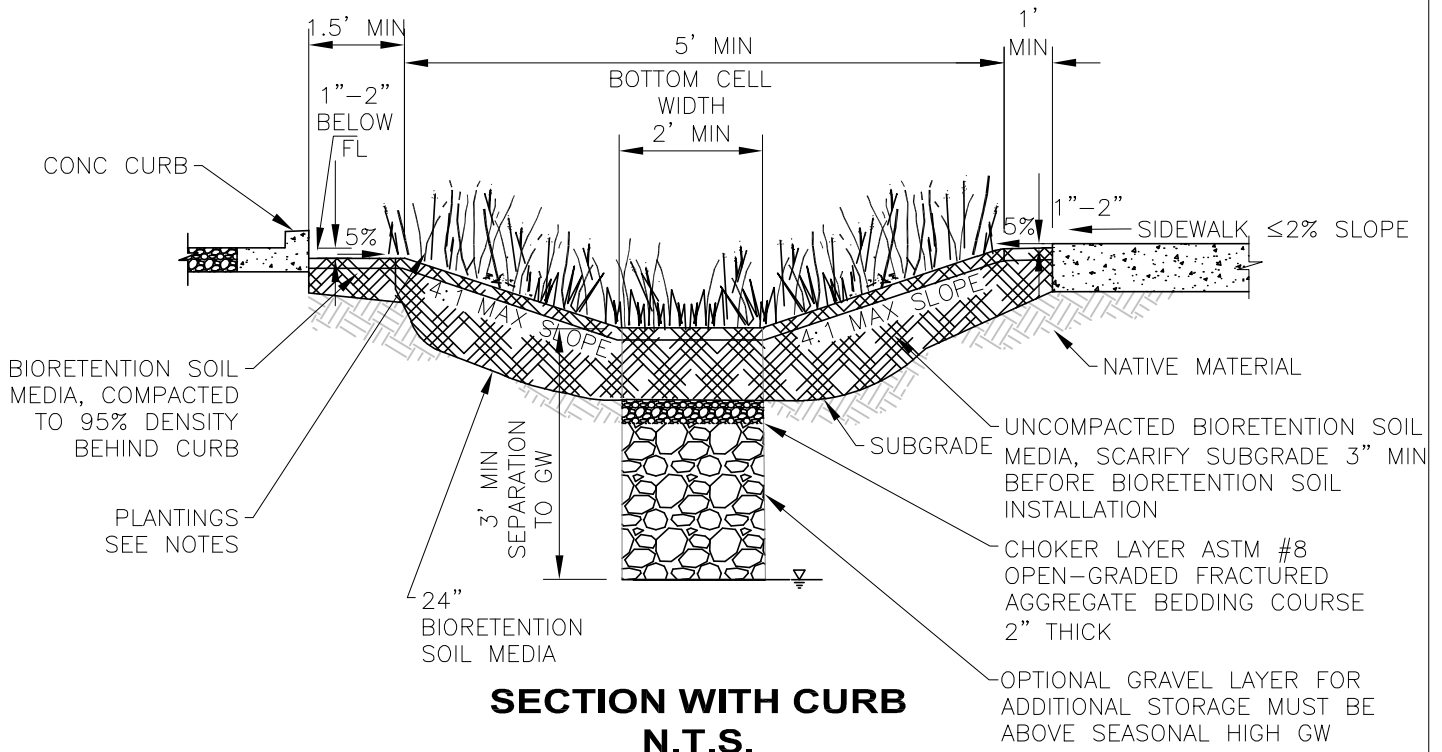

NOTES:
1. SEE NOTES ON SHEET 2 OF 3

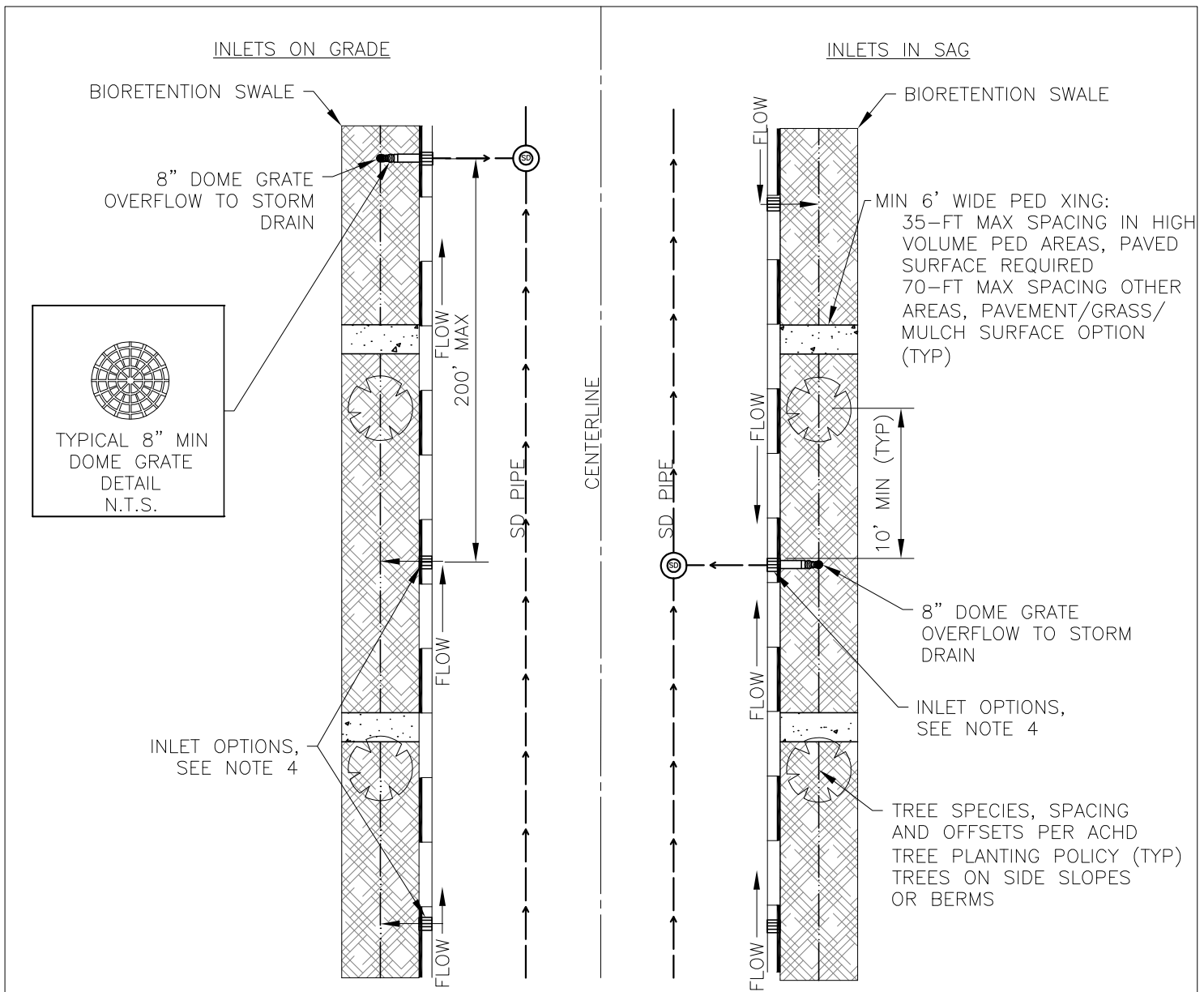

**SWALE WITH SD OVERFLOW
N.T.S.**

NOTES:

1. THE USE OF SWALES MUST BE APPROVED BY ACHD PRIOR TO DESIGN. SWALES ARE NOT ALLOWED ON RESIDENTIAL STREETS FOR NEW DEVELOPMENT EXCEPT RURAL LOTS \geq 1 ACRE
2. SEE SPECIFICATIONS FOR BIORETENTION SOIL MEDIA (BSM)
3. SIDE SLOPES SHALL COMPLY WITH AASHTO CLEAR ZONE GUIDELINES: 3:1 MAX SLOPE < 45 MPH, 4:1 MAX SLOPE \geq 45 MPH
4. SEE BMP 31, SHT 2 OF 2 FOR INLET OPTIONS WITH CURB.
5. FOR DENSE URBAN DETAIL, OPTIONAL OVERFLOW PIPE AND RISER TO BE USED IF ADDITIONAL CAPACITY IS NEEDED
6. STEP OUT ZONE REQUIRED WHEN PARALLEL PARKING IS PROVIDED. FINISHED SURFACE MAY BE CONCRETE SIDEWALK, SOD, MULCH OR PAVEMENT BASED ON SURROUNDING CONDITIONS. MEET CURRENT ADA REQUIREMENTS
7. DEPTH OF SWALE AS SHOWN ON DESIGN PLANS SHOULD BE SIZED TO ADDRESS STORMWATER MANAGEMENT REQUIREMENTS
8. INFILTRATION RATE OF NATIVE SOILS AT SUBGRADE SHALL BE MIN 0.5 IN/HR
9. BIORETENTION CELLS ALLOW PLACEMENT OF AN AGGREGATE SUBBASE FOR ADDITIONAL VOLUMETRIC STORAGE IF NEEDED
10. VEGETATE WITH DROUGHT TOLERANT PLANT SPECIES, WASHED SOD OR SANDY SOD
11. IRRIGATION TO BE DESIGNED FOR SPECIFIC APPLICATION

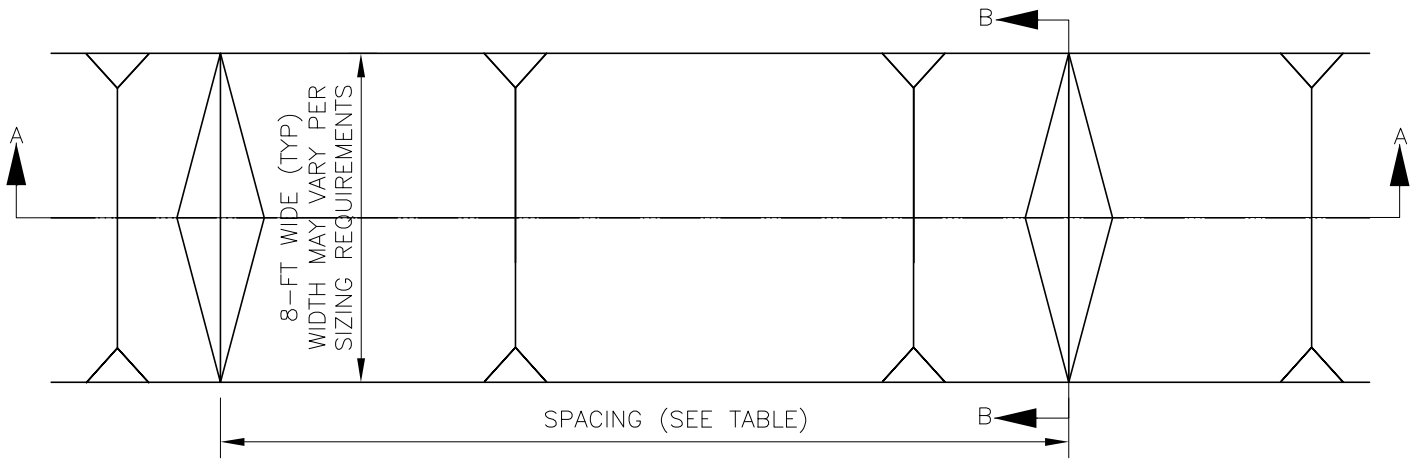

PLAN
N.T.S.
SPACING (SEE TABLE)

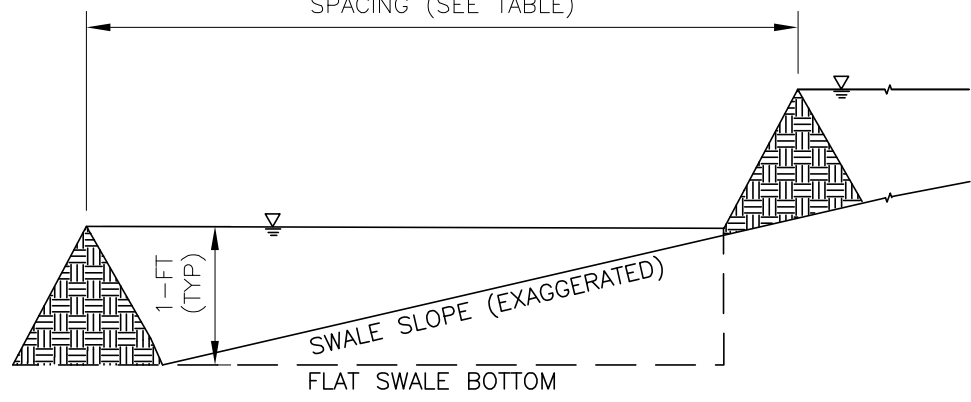

SECTION A-A
N.T.S.

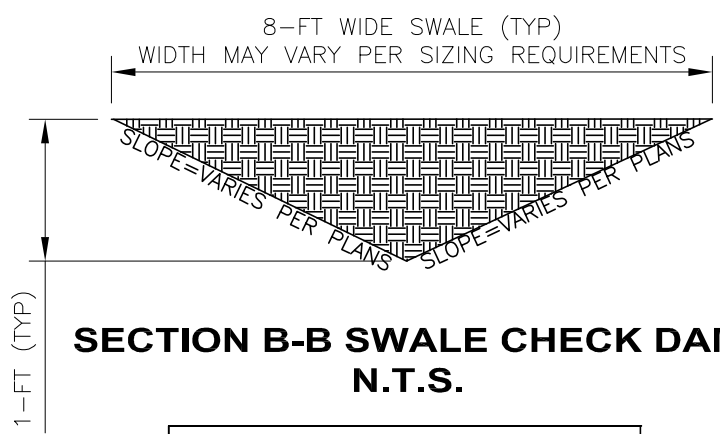

SECTION B-B SWALE CHECK DAM
N.T.S.

PERCENT SLOPE	DIST BETWEEN CHECK DAMS (FT)
1%	100
2%	50
3%	33
4%	25
>=5%, 10% MAX	20

- NOTES:
- CHECK DAMS TO BE CONSTRUCTED OF CLAY SOIL TO MINIMIZE SEEPAGE OR COBBLES FOR CONVEYANCE SWALES. OTHER MATERIALS MAY BE USED FOR CHECK DAMS WITH ACHD WRITTEN APPROVAL
 - SIDE SLOPES AND CHECK DAMS SHALL COMPLY WITH AASHTO CLEAR ZONE GUIDELINES

8202.28 BMP 31 Bioretention Planter

Description

Bioretention planter refers to a bioretention facility with walled vertical sides on all sides of the facility, a flat bottom area, and a large surface capacity to capture, treat, and manage stormwater runoff from a contributing area.

Design

Planters shall have a 4" minimum height wall adjacent to sidewalk for pedestrian safety.

Planter walls shall be made of stone, concrete, brick, or other durable material. Chemically treated wood can contaminate stormwater and shall not be used.

Planter minimum widths are typically associated with their application. ACHD requires:

- 4' minimum for planters in ROW with trees
- 2' minimum for planters without trees

The depth of the planter is measured from the adjacent pedestrian walking surface to the facility finished elevation (planting surface) based on desired ponding plus freeboard. The depth also relates to planter width.

Planters can be deeper if they are wider, and need to be shallower as they narrow. This is a pedestrian perception and safety issue. Some recommended width to depth guidelines are:

PLANTER WIDTH	MAX. PLANTER DEPTH
>5'	16"
4'-5'	12"
3'-4'	10"
2'-3'	8"

Planters are designed as flat facilities that shall not slope more than 0.5 percent in any direction. A minimum of two inches of freeboard (vertical distance between the design water surface elevation and overtopping elevation) shall be provided.

When the sidewalk drains to the planter, provide 4"-6" wide notch openings in wall, 1" below sidewalk sloping to the facility.

Provide minimum 2" cover between notch and structural dowels in curbs/walls.

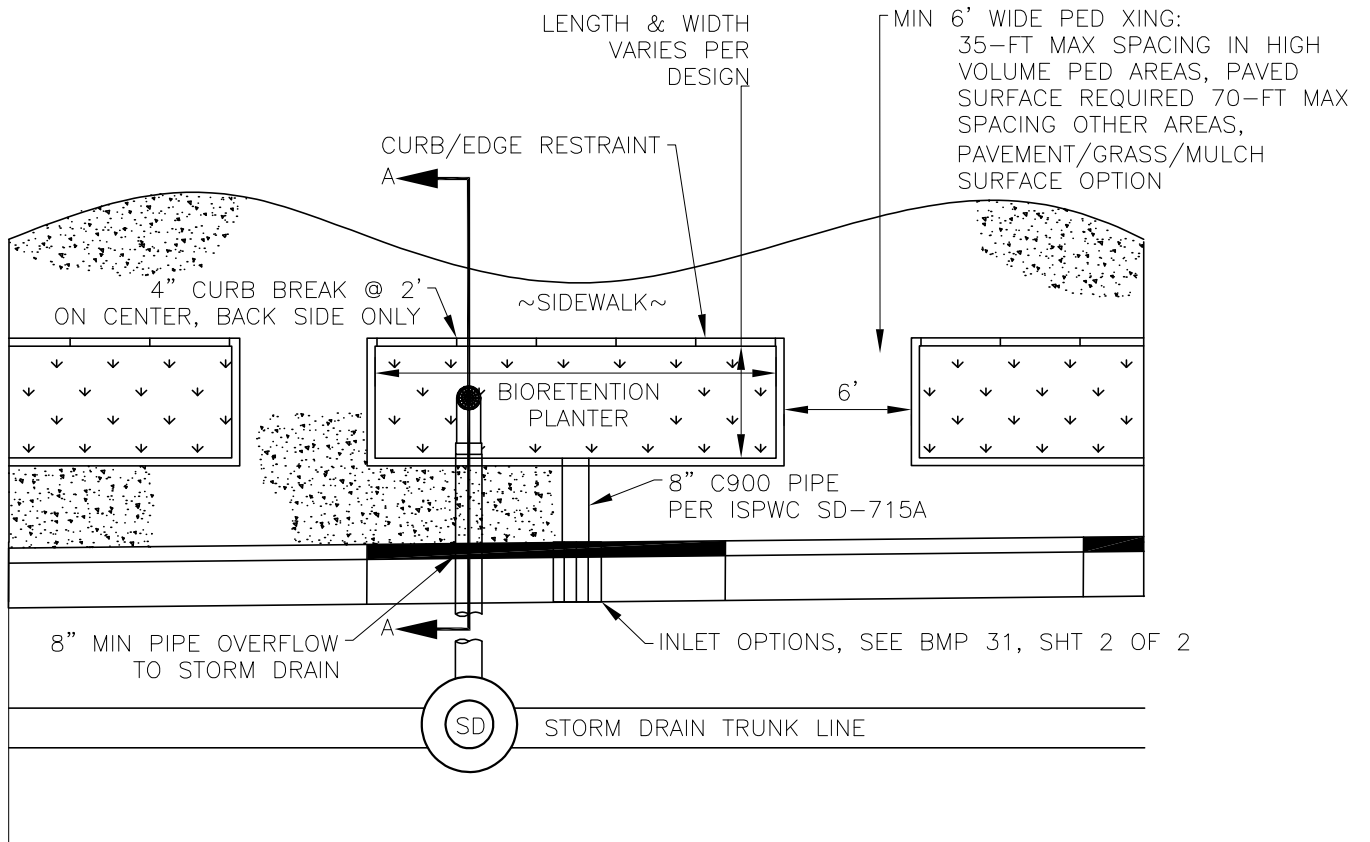

**PLAN
N.T.S.**

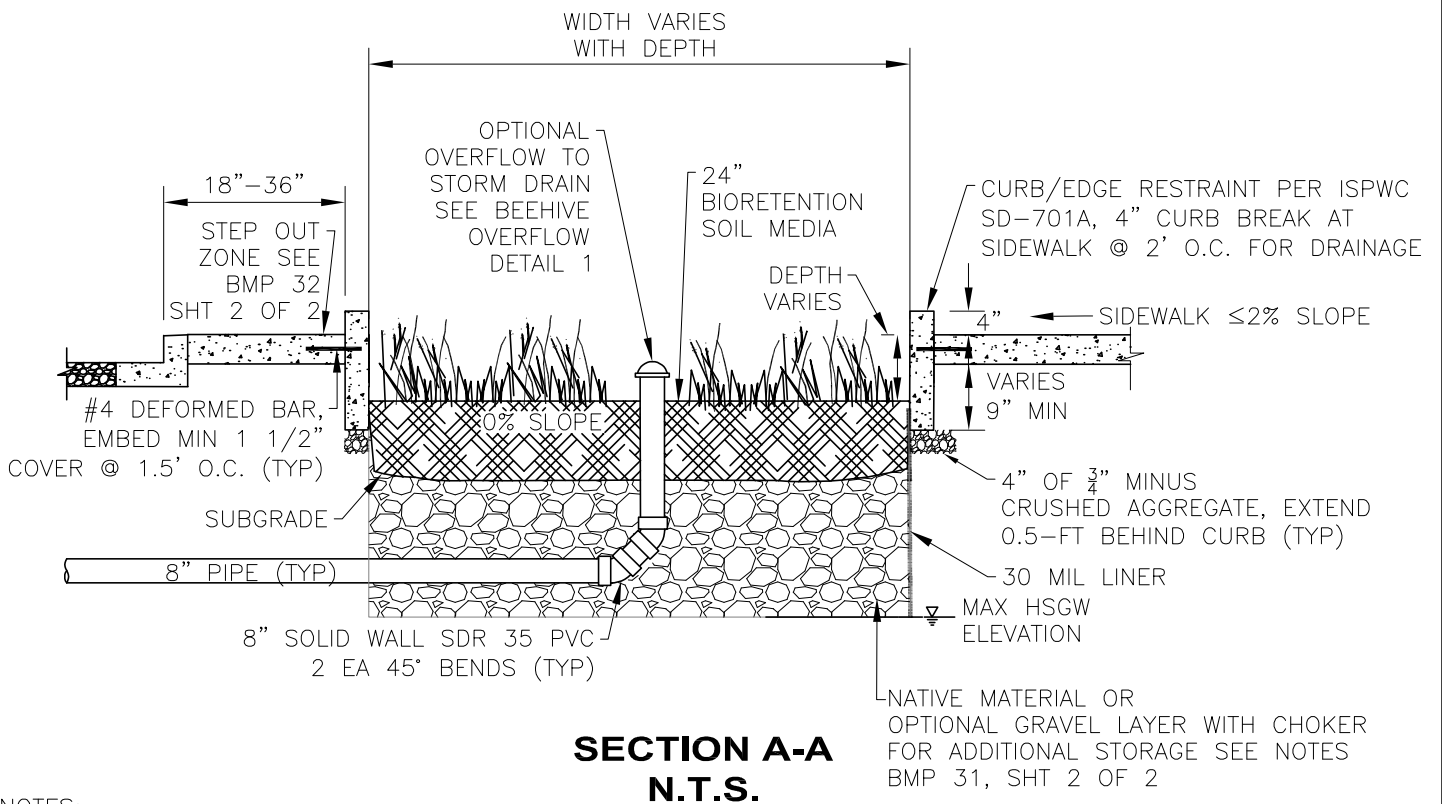

**SECTION A-A
N.T.S.**

NOTES:

1. SEE NOTES ON BMP 30, SHEET 2 OF 3
2. IRRIGATION TO BE DESIGNED FOR SPECIFIC APPLICATION

NOTES:

1. FOR SWALE INLET OPTIONS ON CURB STREET SECTIONS, SEE THE FOLLOWING DETAILS IN THE ISPWC & ACHD SUPPLEMENT TO THE ISPWC:
 - A. SD-715 SHALLOW INLET DETACHED WALK
 - B. SD-715A SHALLOW INLET ATTACHED WALK
 - C. SD-716 CURB OPENING INLET
2. FOR OPTIONAL GRAVEL LAYER, CHOKER SHALL USE ASTM #8 OPEN-GRADED FRACTURED AGGREGATE BEDDING COURSE 1 1/2" TO 2" THICK.

8202.29 BMP 32 Bioretention Curb Extension (Treatment & Storage)

Description

Bioretention curb extensions, also called stormwater curb extensions, are landscaped areas within the parking zone of a street that capture stormwater runoff in a depressed planting bed. The curb extension can be designed similar to a swale, utilizing infiltration and evapotranspiration for stormwater management. Curb extensions can be used at roadway intersections, midblock, or along the length or block of the roadway, and can be combined with pedestrian crosswalks to increase safety along a roadway. Vegetated curb extensions can provide traffic calming opportunities in addition to stormwater management opportunities.

Design

Curb extensions shall include delineators as shown in the BMP 32 details.

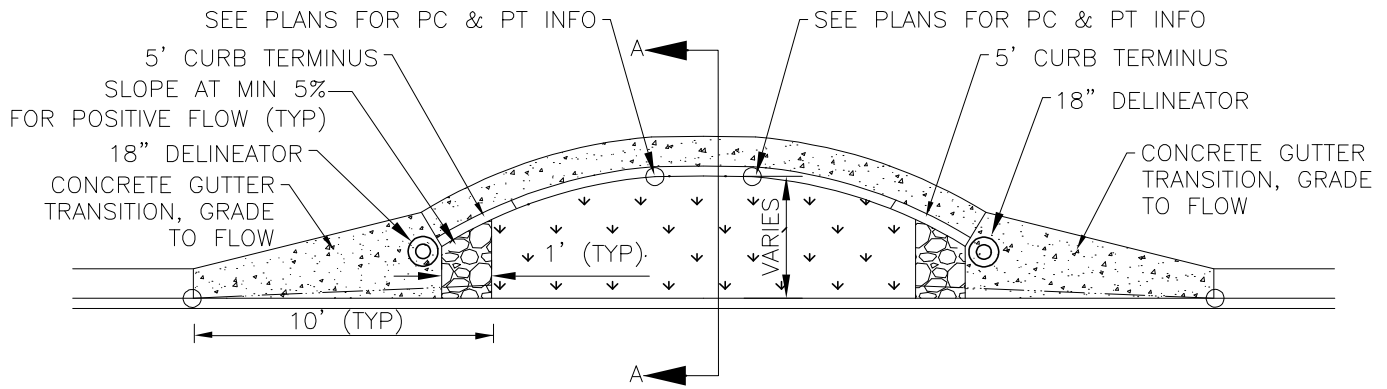

**PLAN
N.T.S.**

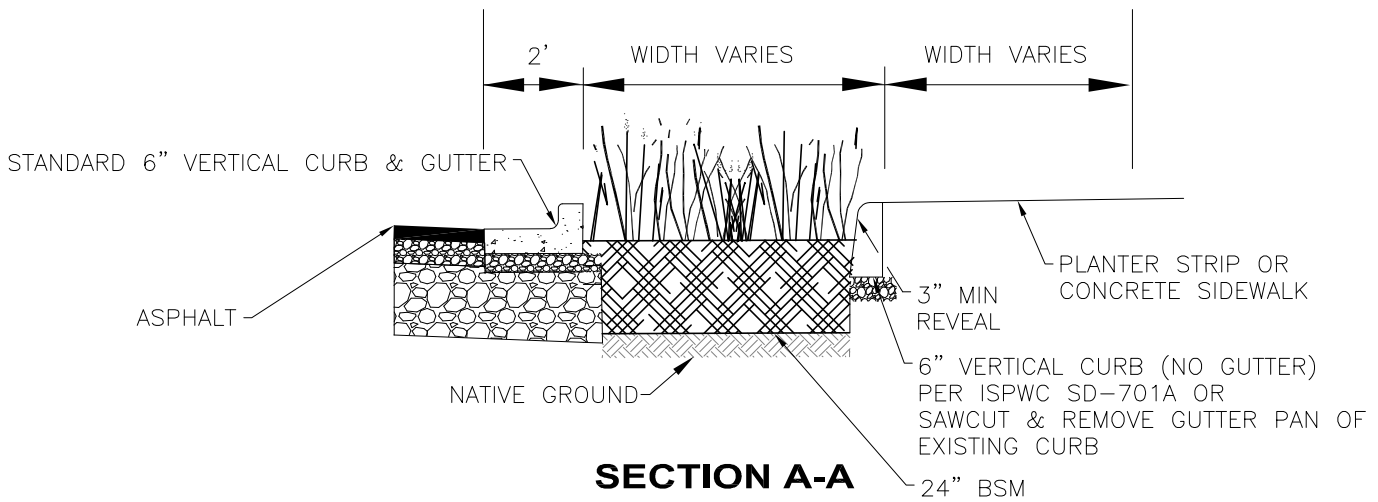

**SECTION A-A
N.T.S.**

NOTES:
1. SEE NOTES ON SHEET 2 OF 2

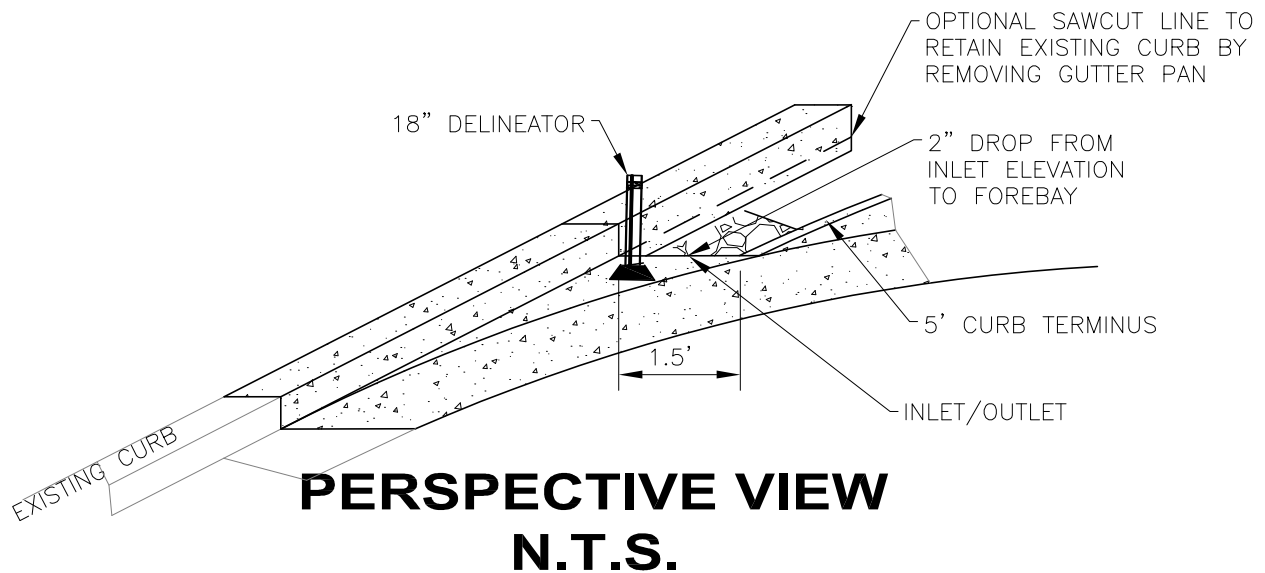
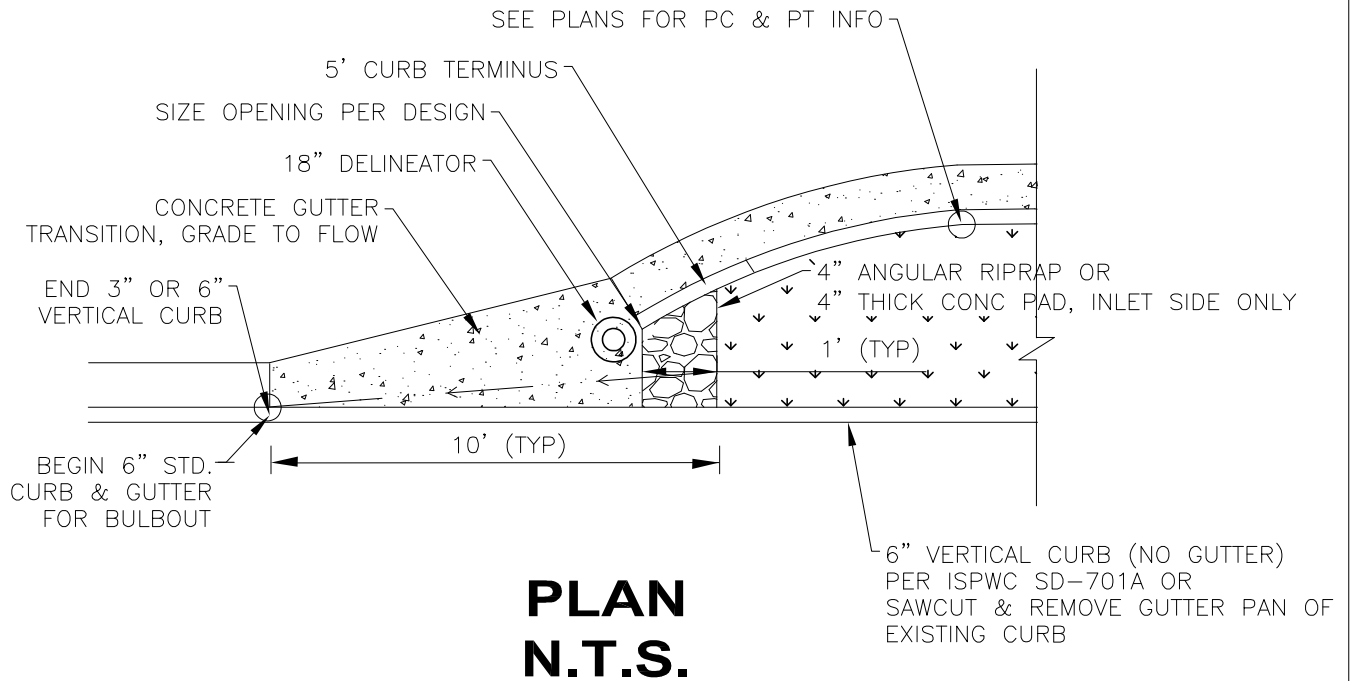

NOTES:

1. SEE SPECIFICATIONS FOR BIORETENTION SOIL MEDIA (BSM)
2. DROUGHT TOLERANT PLANT SPECIES OR WASHED TURF GRASS OVER BSM
3. DEPTH OF INFILTRATION SUMP AS SHOWN ON DESIGN PLANS SHOULD BE SIZED TO ADDRESS STORMWATER MANAGEMENT REQUIREMENTS
4. INFILTRATION RATE OF NATIVE SOILS AT SUBGRADE SHALL BE MIN 0.5 IN/HR
5. BIORETENTION CELLS ALLOW PLACEMENT OF AN AGGREGATE SUBBASE FOR ADDITIONAL VOLUMETRIC STORAGE IF NEEDED.
6. SCARIFY SUBGRADE 3" MINIMUM BEFORE INSTALLATION

8202.30 BMP 33 Stormwater Tree Cells

Description

This BMP is approved for treatment and storage. Stormwater Tree Cells are a pre-engineered modular structural system designed to be filled with a soil mix for tree rooting and designed to support of vehicle loaded pavements. Each soil cell or stack of soil cells shall be structurally independent of all adjacent soil cell stacks such that a single stack or group of stacks can be removed or moved after the completion of installation to facilitate future utility installation and repair.

The structural design of each soil cell unit shall facilitate the movement of roots and water between each cell and between the edges of the cell system and the surrounding soils. The design shall facilitate the installation, compaction and in-situ soil compaction testing; installation and maintenance of utilities within and under the soil cells; the movement and expansion of roots; and the lateral capillary movement of water.

Design

The structural system shall be designed to be filled with a soil mix for tree rooting and to support vehicle-loaded pavements meeting the following requirements:

- The structure shall be designed to support loads up to and including AASHTO H-20 when used in conjunction with approved pavement profiles outside of the travel way.
- Each cell stack shall be structurally independent of all adjacent stacks such that the cell layout can achieve maximum layout flexibility.
- The structural openings must allow all of the soil to be checked for compaction and complete filling of all cell areas.
- The soil cell deck shall be perforated to allow the free flow of water through the deck.
- The soil cells shall have been specifically designed and tested for the purpose of growing tree roots, and rainwater filtering, detention and retention.
- The soil cells shall permit the structure to be built around, over, under and through existing and proposed utilities.

For each type of product, submit manufacturer's product literature with technical data sufficient to demonstrate that the product meets these specifications including:

- Manufacturer's certified analysis for standard products
- Soil cell manufacturer's letter of review and approval of the project, plans, details and specifications for compliance with product installation requirements.

Soil cells and related products shall be installed by a qualified installer whose prior work has resulted in successful installation of planting soils and planter drainage systems, underground piping, chambers and vault structures.

The installer is required to maintain an experienced full-time supervisor on project site when the work is in progress. The installer will be required to take part in a half-day training session provided by the manufacturer. The training session shall be attended by all foremen and key personnel involved in installation.

Refer to manufacturer's instructions for installation of soils cells, planting soil, geo-grid and backfill.

Where needed and approved, utility lines may be installed through the spaces within the soil cell frames.

An observation well shall be provided as an inspection riser for drainage. Install a minimum of one inspection riser for each four trees above the soil cells.

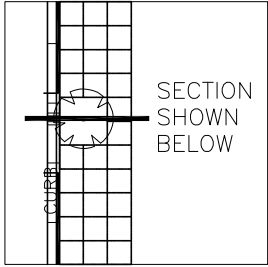

SECTION SHOWN BELOW

KEY PLAN

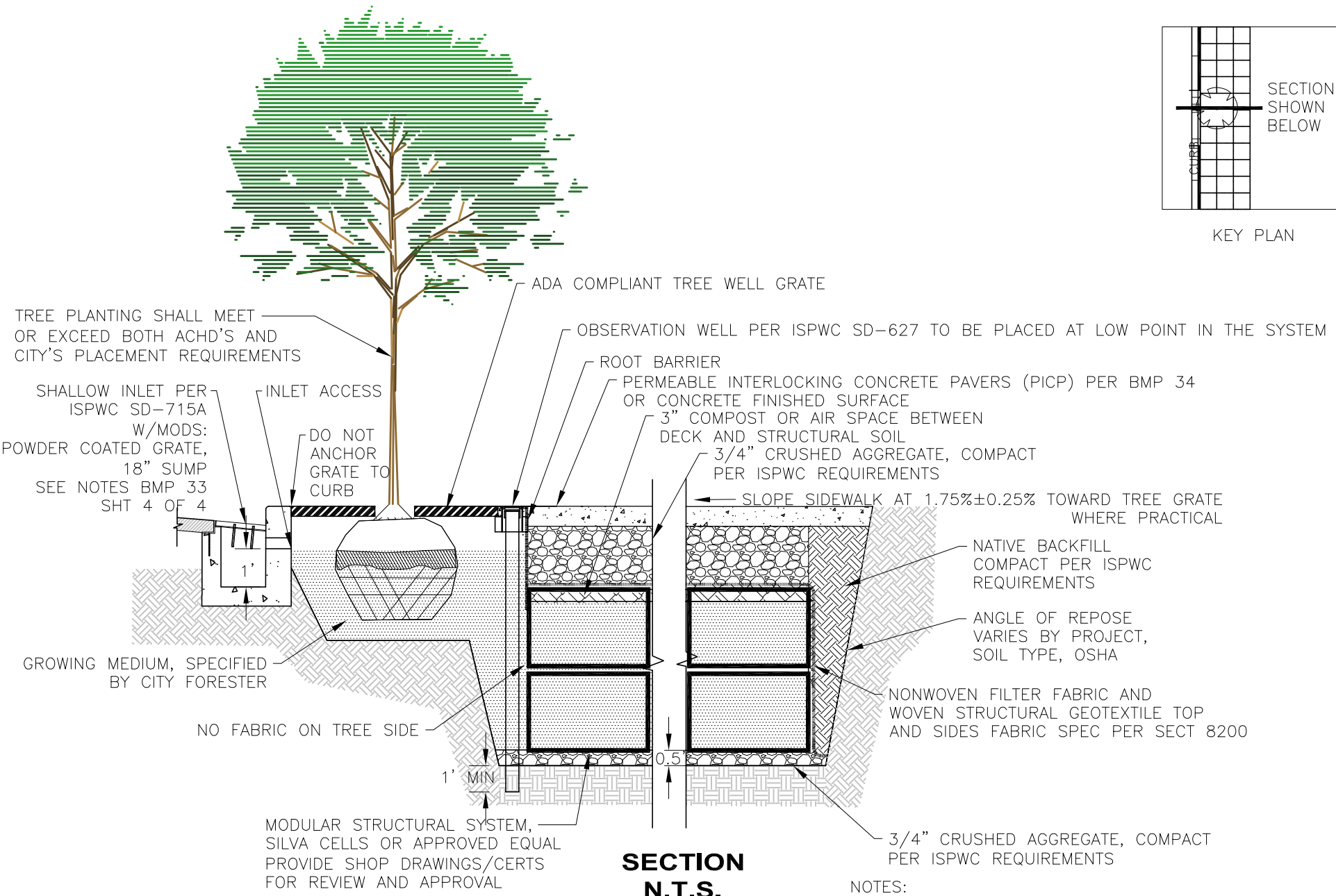

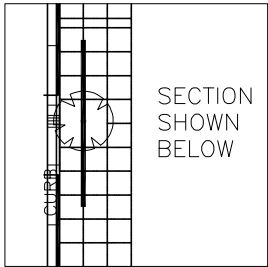

KEY PLAN

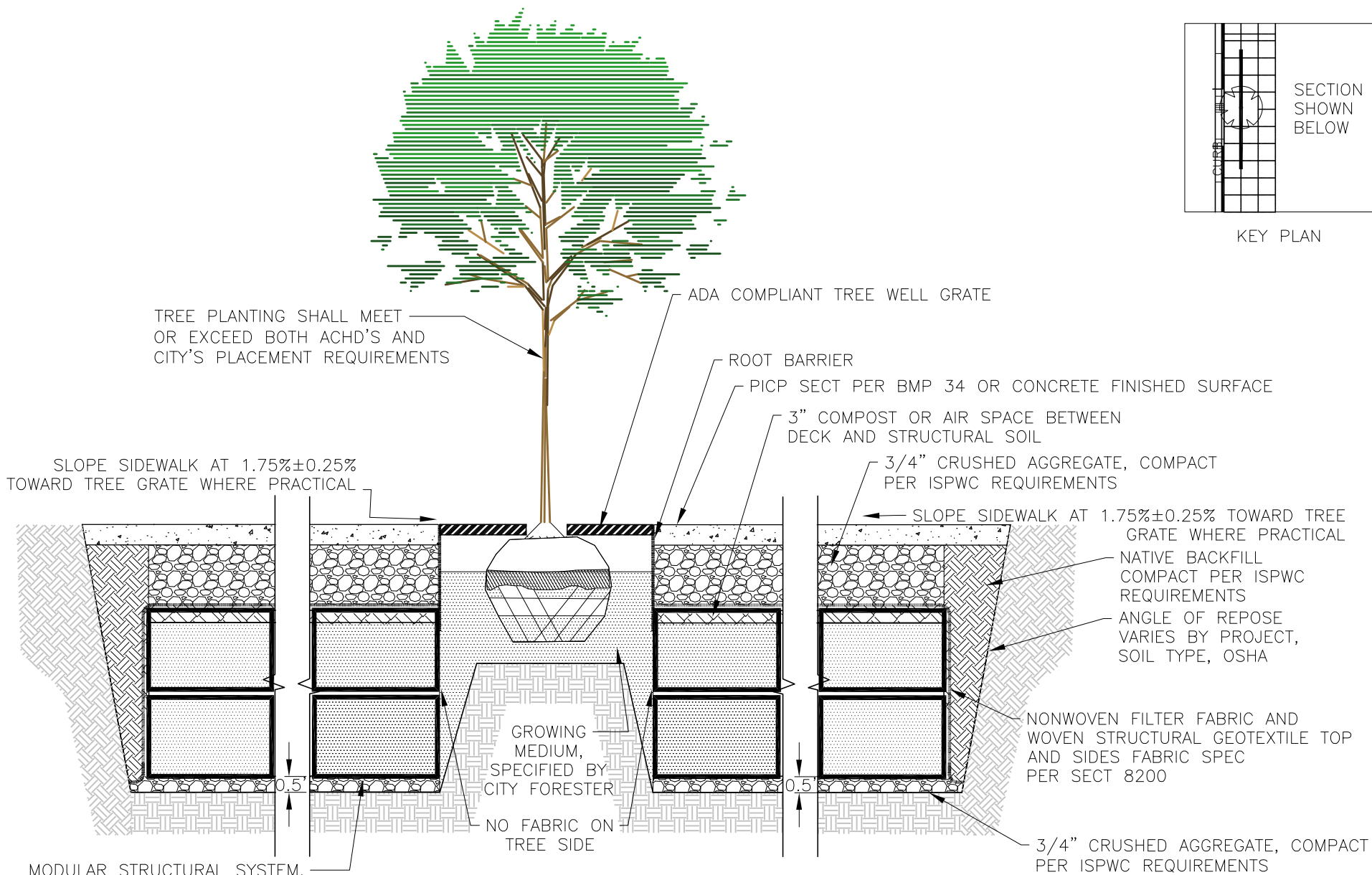

TREE PLANTING SHALL MEET OR EXCEED BOTH ACHD'S AND CITY'S PLACEMENT REQUIREMENTS

SLOPE SIDEWALK AT 1.75%±0.25% TOWARD TREE GRATE WHERE PRACTICAL

ADA COMPLIANT TREE WELL GRATE

ROOT BARRIER

PICP SECT PER BMP 34 OR CONCRETE FINISHED SURFACE

3" COMPOST OR AIR SPACE BETWEEN DECK AND STRUCTURAL SOIL

3/4" CRUSHED AGGREGATE, COMPACT PER ISWPC REQUIREMENTS

SLOPE SIDEWALK AT 1.75%±0.25% TOWARD TREE GRATE WHERE PRACTICAL

NATIVE BACKFILL COMPACT PER ISWPC REQUIREMENTS

ANGLE OF REPOSE VARIES BY PROJECT, SOIL TYPE, OSHA

NONWOVEN FILTER FABRIC AND WOVEN STRUCTURAL GEOTEXTILE TOP AND SIDES FABRIC SPEC PER SECT 8200

3/4" CRUSHED AGGREGATE, COMPACT PER ISWPC REQUIREMENTS

GROWING MEDIUM, SPECIFIED BY CITY FORESTER

NO FABRIC ON TREE SIDE

MODULAR STRUCTURAL SYSTEM, SILVA CELLS OR APPROVED EQUAL PROVIDE SHOP DRAWINGS/CERTS FOR REVIEW AND APPROVAL

SECTION N.T.S.

NOTES:
1. SEE BMP 33 SHT 4 OF 4 FOR NOTES

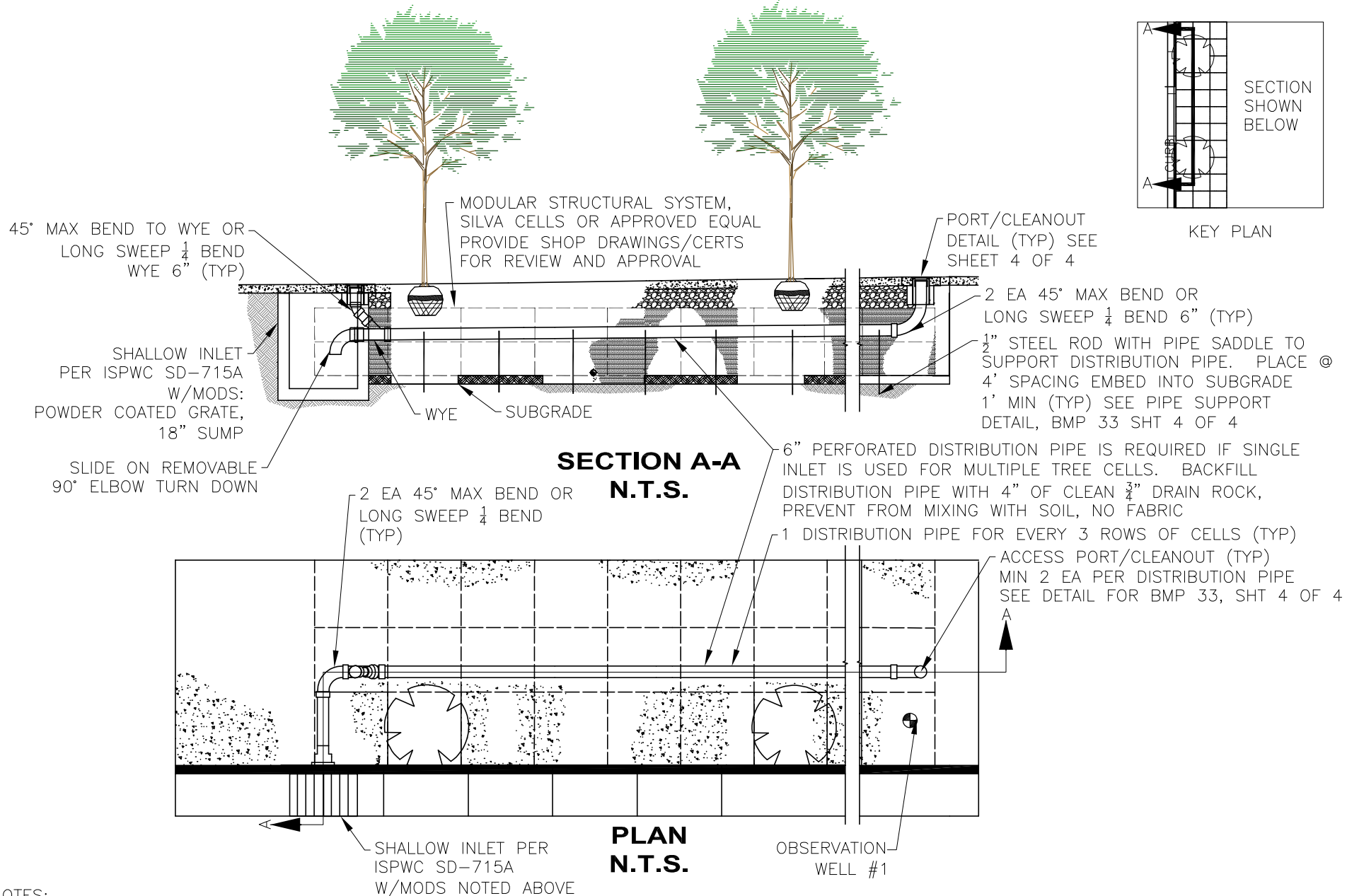

NOTES:
1. SEE BMP 33 SHT 4 OF 4 FOR NOTES

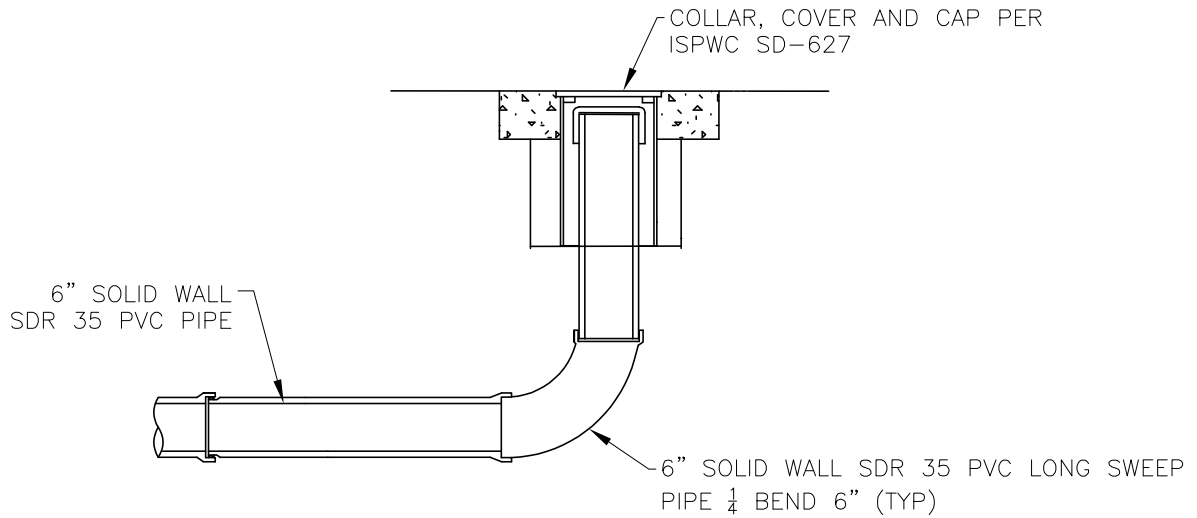

**INSPECTION PORT/CLEANOUT DETAIL
END OF PIPE**

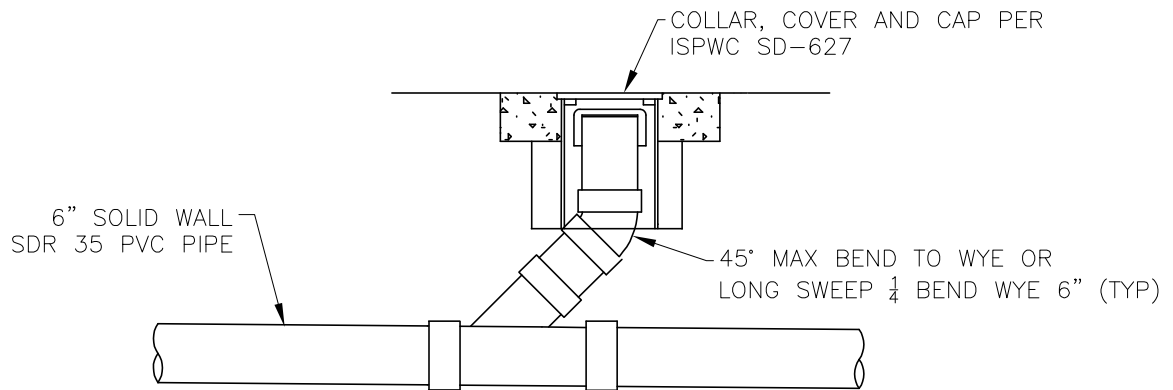

**INSPECTION PORT/CLEANOUT DETAIL
AT WYE**

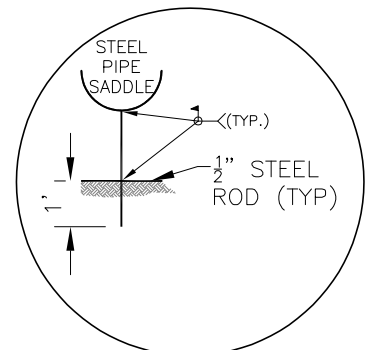

**PIPE SUPPORT DETAIL
N.T.S.**

NOTES:

1. IRRIGATION TO BE DESIGNED FOR SPECIFIC APPLICATION
2. INLET GRATES FOR TREE STORMWATER CELLS SHALL HAVE ENVIROCRON, OR APPROVED EQUAL, POWDER COAT SKY BLUE COLOR APPLIED.

8202.31 BMP 34 Permeable Pavers (Treatment & Storage)

Description

This BMP is approved for treatment and storage. Permeable Interlocking Concrete Pavements (PICP) provide an alternative to conventional pavement systems in lower-speed vehicle areas. They permit stormwater to infiltrate between precast concrete pavers for temporary storage, infiltration into subsurface soils, or discharge to another location once stormwater passes through the pavement structure. PICPs are the only permeable pavement systems currently approved for use. PICPs can be used in local residential streets, parking lanes and alleys in commercial areas. All other applications require prior approval from ACHD staff.

Design

Concrete Block Pavers

1. The surfacing materials for pedestrian and vehicular uses shall consist of concrete paving units that conform to ASTM C936 including an average 8,000 psi compressive strength and minimum 3 1/8 inch thickness.
2. Pavers shall be designed to allow joint spaces between blocks of 5% to 15 % of the total pavement surface.
3. Paver products shall be specified from the ACHD approved list maintained by the Development Review Section. Alternative products may be specified during the review and approval process. Additional pavers required for maintenance activities shall be available as an in stock item from a local supplier.

Subgrade

PICP subgrade shall be tested and approved by a qualified geotechnical engineer, and written approval provided to ACHD. Properties and conditions to be evaluated include but are not limited to:

1. Soil classification as per ASTM D2487
2. Soil subgrade strength
3. Infiltration rate (permeability testing as per ASTM D3385)

Aggregates

1. PICP aggregate shall be crushed with 90% fractured faces and a minimum Los Angeles Abrasion factor of less than 40 per ASTM C131 and C535.
2. Gap aggregate shall conform to ASTM sizes No. 8 stone.
3. Open graded bedding course (1.5 inch minimum thickness) shall conform to ASTM No. 8 stone.
4. Open graded base reservoir (4 inch minimum thickness) shall conform to ASTM No. 57 stone (1 to 1.5 inch crushed stone).
5. Open graded subbase reservoir shall conform to ASTM No. 2,3, or 4 stone (2 to 3 inch)
6. Aggregates should be washed and contain no fines.

General Design Criteria

1. PICP shall be designed by a registered professional.
2. All Section 8000 Infiltration Requirements apply.

3. A survey shall be submitted showing calculations of the exact dimensions of all existing impervious surfaces and of the project site before and after completion of the project.
4. One-hundred (100) percent of the total area covered by PICP shall be considered a pervious or permeable surface.
5. In subdivisions, PICP surfaces shall have a longitudinal slope between 0.0% to 2%. PICP systems shall have a 0% surface and subgrade cross slope. For alleys and retrofit projects, longitudinal slopes up to 6% are allowed and may require the installation of terraces and baffles to achieve flat subgrades under sloping pavement surfaces.
6. PICP should not be used if located next to ground slopes in excess of 20%.
7. The surface of the soil subgrade shall have a longitudinal slope of less than or equal to the longitudinal slope of the PICP surface.
8. PICP section design will be governed by the deepest section required for either structural performance or stormwater capacity.
9. Structural design method shall be in conformance to the AASHTO Flexible Pavement Design Method or ASCE Standard 58-10 / Structural Design of Interlocking Concrete Pavement for Municipal Streets and Roadways.
10. Void ratio for base aggregates is 0.4 (40% void space). For design purposes, only the base and subbase courses can be used as storage volume.
11. Subgrade surface shall drain 90% of the storage volume within 48 hours.
12. All manufacturer requirements, product standards, and industry guidelines shall be followed to ensure lasting effectiveness of PICP systems.
13. The surface of the soil subgrade under infiltrating PICP shall not become compacted during construction. If compaction occurs then the surface shall be scarified, ripped, or trenched immediately prior to aggregate base placement to maintain the pre-construction subgrade infiltration rate.
14. PICP systems designed for infiltration shall treat the design storm. PICP systems designed for detention shall be designed to meet runoff reduction requirements and provide safe conveyance for storms of larger magnitude.
15. PICP systems may be designed to receive runoff from adjacent built upon areas (BUAs) such as roofs and conventional roadway pavement (if the soils under the permeable pavement have adequate capacity to infiltrate the additional runoff). The design shall provide storage for the entire runoff volume. In addition, the system shall be designed to convey the runoff from the adjacent BUAs to the permeable pavement. Runoff from private parking areas shall not be allowed for new roadways.
16. Runoff from concentrated flow, such as roof drains, must be discharged onto the top of the PICP surface. If possible, run on flows shall be dispersed (sheet flow conditions) prior to discharge to the PICP surface. Stormwater discharge directly into the PICP base materials is not permitted.
17. For alleys and retrofit projects, maximum allowable run on (from adjacent impermeable surfaces to PICP surfaces) ratio is 3:1. Run on rates of up to 5:1 will be considered on a case by case basis but must be approved by ACHD.

18. Runoff from adjoining pervious areas, such as grassed slopes and landscaping shall be prevented by grading the landscape away from the permeable pavement.
19. After installations, BMPs shall be installed as per the required SWPPP to minimize construction traffic impact and debris track out onto the PICP.
20. The soil subgrade for the PICP shall be graded when dry. The aggregate base and permeable surface course shall be completed as quickly as possible to reduce risk of soil subgrade compaction.
21. PICP may be placed on fill material as long as the material is at least as permeable as the in-situ soil after it is placed and prepared. Design shall be based upon the most restrictive soil.
22. In subdivisions, a minimum of two observation wells shall be provided every 1,000 linear feet and at the low point in the system. One well shall be placed within the roadway prism and the other shall be no more than 20 feet away, and located at the back of the sidewalk. An outside well is not required for alley retrofit projects.
23. In subdivisions, edge restraints shall be provided around the perimeter of PICP as well as anywhere PICP is adjacent to conventional asphalt. Edge restraints shall consist of concrete curbing or a ribbon curb having a minimum width of 8 inches and a minimum depth of eighteen inches. Two foot transitions to and from vertical curb to rolled curb and back shall be utilized.
 - a. Curb in front of residential lots shall be rolled reverse lip curb
 - b. Curb in front of common lots shall be either 6 inch vertical reverse lip curb or 18 inch vertical curb.
24. Water and sewer services shall have at least one foot of subgrade cover under the PICP system.
25. For new construction, sidewalk for PICP shall be attached only.
26. Linear partial street width installations (parking areas) shall maintain a minimum ten foot wide asphalt pavement surface from roadway crown (centerline).
27. Partial street installations are not allowed in cul-de-sacs, bulb-outs and knuckles.
28. Concrete collars are required for all utility lids (e.g. Manholes, water valves, monitoring wells, etc.). Care shall be taken to insure collars are square with the paver pattern. Use of integral color to match the PICP is encouraged. Surface staining/coloring of concrete collars is prohibited.

Installation Requirements

1. PICP systems shall be installed by a contractor that has an Interlocking Concrete Pavement Institute (ICPI) Concrete Paver Installation Certification. Documentation of certified installers shall be provided prior to the scheduling of a preconstruction conference.
2. Certified installer shall be onsite to oversee each installation crew during all PICP construction.
3. Contractor shall provide a Phasing Plan for the installation, which shall clarify that the utilities will be installed prior to excavation of the subgrade, including joint trench and all underground utilities.

Infiltration Testing Requirements

1. The subgrade shall be tested to ensure the infiltration rate is at least 0.5 inch per hour or greater.

2. In subdivisions, testing shall be performed during design to obtain the design infiltration rate, immediately prior to placing the paver subbase to confirm the design infiltration rate and post construction prior to acceptance.
3. For subdivisions, the subgrade shall be tested every 1,000 linear feet. Additional testing may be required if the soil type is proven to be inconsistent or if warranted during post construction acceptance testing.

Signage

For alleys and retrofit projects, permeable pavement signage shall be clearly and permanently posted to prevent use by inappropriate vehicles, and the deposition and storage of particulate matter.

Warranty Period/Development Agreement

For all new subdivisions, PICP systems shall be subject to the standard 2-year warranty required by ACHD for all streets. Additionally, a development agreement specific to this BMP shall be required prior to plans acceptance.

The development agreement shall, at a minimum, address the following:

- Design, Construction and Installation of the PICP system
- Maintenance Manual/Maintenance requirements
- Post construction infiltration testing
- Requirements for SWPP to be submitted by the Developer to include:
 - Sediment and Mud Tracking Prevention/Provisions through build out or stabilization of 100 % of the homes/adjacent lots
 - Sweeping and Maintenance of PICP system through build out or stabilization of 100% of the homes/adjacent lots
- Financial Surety to cover the cost to replace 100% of the joint aggregate.
- Penalties/Enhanced fees for failure to comply with the terms of the development agreement

Paver Replacement

Damaged pavers or pavers replaced for installation and/or repair of subsurface utilities must be replaced per manufacturer's specifications and must be a color match to the existing paver pattern.

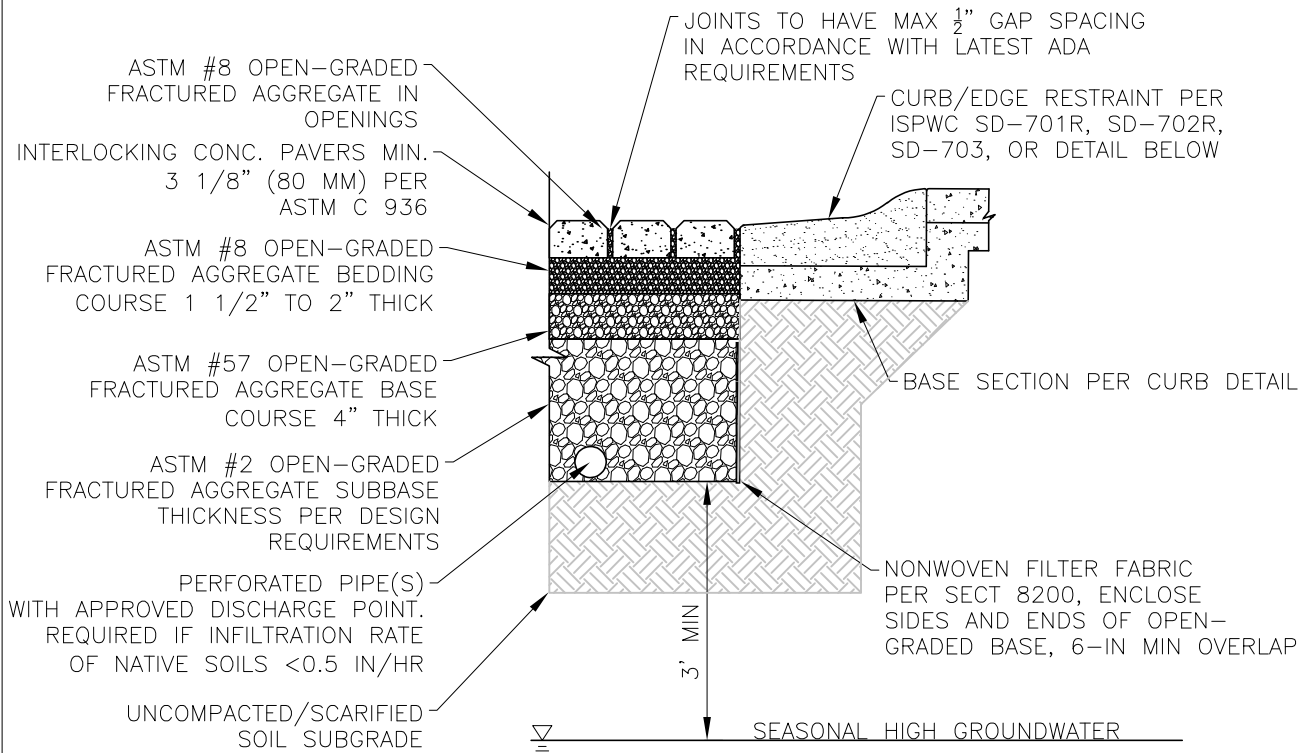

**SECTION
N.T.S.**

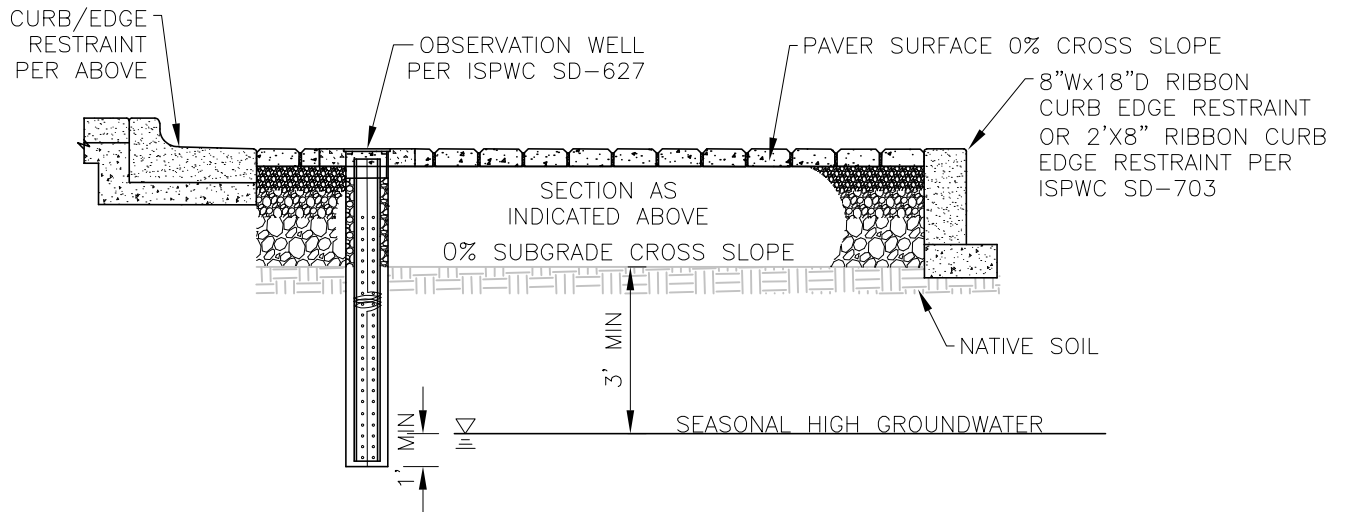

**STREET OR ALLEY SECTION
N.T.S.**

NOTES:

1. USE OF PERMEABLE INTERLOCKING CONCRETE PAVERS (PICP) IN PUBLIC STREETS REQUIRES ACHD APPROVAL PRIOR TO DESIGN OR SHALL MEET THE REQUIREMENTS OF ACHD POLICY SECT 8202. AGREEMENT FOR PROTECTION AND MAINTENANCE OF PICP IS REQUIRED.
2. INTERLOCKING CONCRETE PAVEMENT INSTITUTE (ICPI) CERTIFIED INSTALLER IS REQUIRED. INSTALLER TO PROVIDE CERTIFICATIONS PRIOR TO PLACEMENT.
3. PICP SHALL MEET REQUIREMENTS OF ACHD SECTION 8010 INFILTRATION REQUIREMENTS.
4. 0% CROSS SLOPE ON PAVER SURFACE AND SUBGRADE.
5. MAXIMUM LONGITUDINAL GRADE IS 2.0%.
6. FOR USE WITH ATTACHED SIDEWALK OR ALLEYS ONLY.
7. AGGREGATES SHALL MEET ASTM STANDARDS AND ICPI PERMEABLE INTERLOCKING CONCRETE PAVEMENT (PICP) MANUAL, CURRENT EDITION.
8. OBSERVATION WELL PER ISPWC SD-627. OBSERVATION WELLS ARE REQUIRED AT THE LOW POINTS, IN THE PAVER SECTION AND OUTSIDE. OUTSIDE WELL TO EXTEND MIN 1' BELOW SEASONAL HIGH GROUNDWATER. OUTSIDE WELLS ARE NOT REQUIRED IN ALLEYS.
9. PAVER PRODUCTS PER ACHD APPROVED LIST. SEE DEVELOPMENT SERVICES FOR CURRENT LIST.
10. REVERSE PAN VERTICAL CURBING SHALL ONLY BE PLACED ALONG MEDIAN ISLANDS AND COLLECTOR ROADWAYS THAT DO NOT CONTAIN FRONT-ON-HOUSING. REVERSE PAN ROLLED CURBING SHALL ONLY BE USED FOR ROADWAY SECTIONS THAT CONTAIN FRONT-ON-HOUSING. RIBBON CURBING SHALL ONLY BE USED ALONG ALLEYWAYS.
11. UTILITY WORK, INCLUDING JOINT TRENCH AND ALL UNDERGROUND UTILITIES, SHALL BE COMPLETED PRIOR TO EXCAVATION OF SUBGRADE AND PLACEMENT OF BALLAST SECTION AND PICP.

APPENDIX A

Ada County IDF Curve

Boise Area Intensity-Duration-Frequency (IDF)

Intensity (inches per hour)

	Design Storm	2	5	10	25	50	100
Tc (Hr)	Tc (Min)	=====					
0.17	10 min	0.69	1.15	1.45	1.85	2.20	2.58
0.25	15 min	0.59	0.97	1.22	1.56	1.86	2.18
0.33	20 min	0.49	0.81	1.01	1.30	1.54	1.81
0.42	25 min	0.43	0.71	0.89	1.14	1.35	1.58
0.50	30 min	0.41	0.67	0.85	1.08	1.29	1.51
0.58	35 min	0.34	0.56	0.70	0.90	1.07	1.25
0.67	40 min	0.31	0.51	0.64	0.82	0.98	1.15
0.75	45 min	0.29	0.48	0.60	0.77	0.91	1.07
0.83	50 min	0.27	0.45	0.56	0.72	0.85	1.00
0.92	55 min	0.26	0.43	0.54	0.69	0.82	0.96
1.00	1 hour	0.26	0.43	0.54	0.69	0.82	0.96
2.00	2 hours	0.16	0.25	0.31	0.39	0.46	0.54
3.00	3 hours	0.13	0.19	0.23	0.29	0.34	0.40
6.00	6 hours	0.09	0.12	0.14	0.18	0.21	0.25
12.00	12 hours	0.06	0.08	0.10	0.12	0.14	0.16
24.00	24 hours	0.04	0.06	0.06	0.08	0.09	0.10

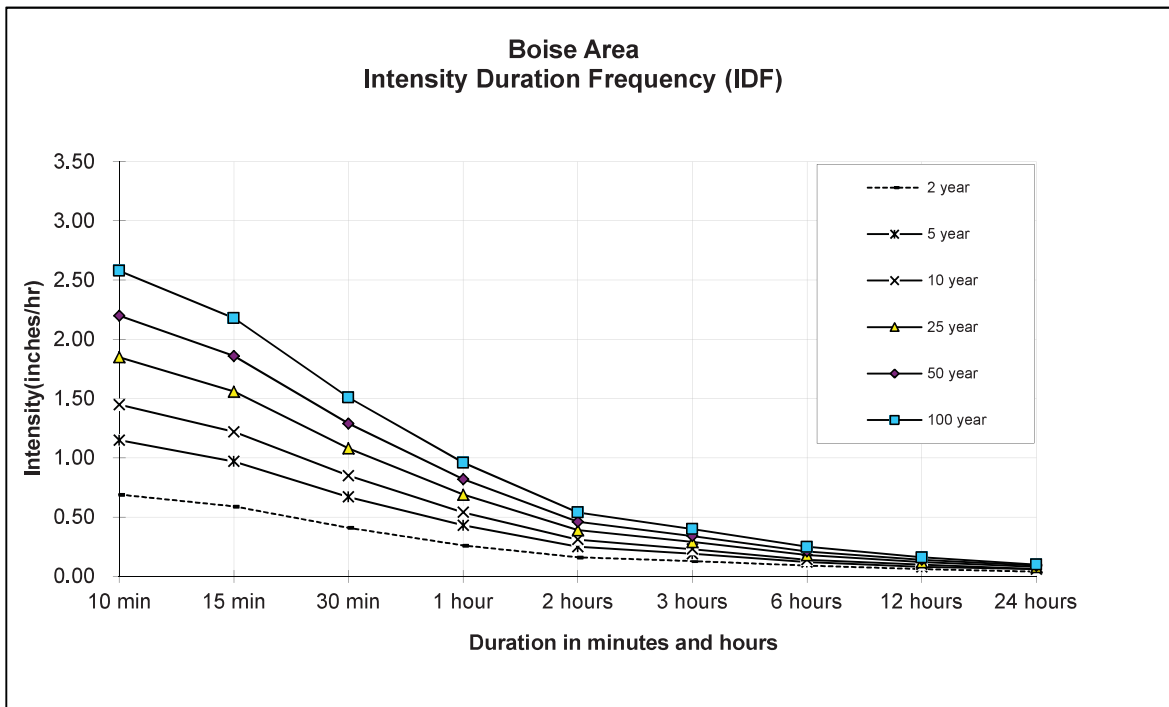

APPENDIX B

Infiltration Testing Methods

A. In-Situ Small-Scale Pilot Infiltration Test Method

Small-scale Pilot Infiltration Tests (PITs) shall be used for measuring the saturated hydraulic conductivity of the soil profile beneath facilities in areas with homogeneous soils where the required separation distance from groundwater and bedrock can be achieved.

1. Test Procedure

The test method is the following:

- a. Excavate the test pit to the estimated infiltration elevation of the proposed facility.
- b. The horizontal surface area of the bottom of the test pit should be twelve to thirty-two square feet (12-32 SF). The pit may be circular or rectangular, but accurately document the size and geometry of the test pit.
- c. Install a vertical measuring rod adequate to measure the full ponded water depth and marked in half-inch increments in the center of the pit bottom.
- d. Use a rigid pipe with a splash plate on the bottom to convey water to the pit and reduce side-wall erosion or excessive disturbance of the infiltration surface. Excessive erosion and bottom disturbance will result in clogging of the infiltration receptor and yield lower than actual infiltration rates.
- e. Pre-soak period: add water to the pit so there is standing water for at least six (6) hours. Maintain the pre-soak water level at least twelve (12") inches above the bottom of the pit.
- f. At the end of the pre-soak period, add water to the pit at a rate that will maintain a six to twelve (6- 12") inch water level above the bottom of the pit over a full hour. The specific depth should be the same as the maximum designed ponding depth.
- g. Every fifteen (15) minutes, record the cumulative volume and instantaneous flow rate in gallons per minute necessary to maintain the water level at the same point on the measuring rod.
- h. After one (1) hour, turn off the water and record the rate of infiltration in inches per hour from the measuring rod data until the pit is empty.
- i. At the conclusion of testing, over-excavate the pit to see if the test water is mounded on shallow restrictive layers or if it has continued to flow deep into the subsurface. The depth of excavation varies depending on soil type and depth to hydraulic restricting layer, and is determined by an Idaho registered geologist, professional engineer, or professional soil scientist with experience in hydrogeologic investigations.

2. Data Analysis

- a. Calculate and record the saturated hydraulic conductivity in inches per hour in thirty (30) minute or one (1) hour increments until one (1) hour after the flow has stabilized.
- b. Use statistical/trend analysis to obtain the hourly flow rate when the flow stabilizes. This would be the lowest hourly flow rate.
- c. Apply appropriate factor of safety (FOS) to determine the site-specific design infiltration rate with a minimum FOS of two (2).

B. In-Situ Large-Scale Pilot Infiltration Test (PIT) method

Large-scale in-situ PITs shall be used for measuring the saturated hydraulic conductivity of the soil profile beneath facilities in areas where conditions are not uniform.

1. Test Procedure

The test method is the following:

- a. Excavate the test pit to the estimated elevation of the proposed infiltration surface. Lay back the slopes sufficiently to avoid caving and erosion during the test.
- b. The horizontal surface area of the bottom of the test pit should be at least one-half (1/2) the size of the proposed facility. Accurately document the size and geometry of the test pit.
- c. Install a vertical measuring rod in the center of the pit bottom.
- d. Use a rigid six (6") inch diameter pipe with a splash plate on the bottom to convey water to the pit and reduce side wall erosion or excessive disturbance of the basin bottom.
- e. Add water to the pit at a rate that will maintain a water level between six and twelve (6 and -12") inches above the bottom of the pit.
- f. Every fifteen to thirty (15-30) minutes, record the cumulative volume and instantaneous flow rate in gallons per minute necessary to maintain the water level at the same point on the measuring rod.
- g. Keep adding water to the pit until one (1) hour after the flow rate into the pit has stabilized while maintaining the same water level. A stabilized flow rate should have a variation of five (5%) percent or less in the total flow. The total of the pre-soak time plus the one (1) hour after the flow rate has stabilized should be no less than six (6) hours.
- h. After the flow rate has stabilized for at least one (1) hour, turn off the water and record the rate of infiltration in inches per hour per hour from the measuring rod data, until the pit is empty. Consider running this falling head phase of the test several times to estimate the dependency of infiltration rate with head.

- i. At the conclusion of testing, over-excavate the pit to see if the test water is mounded on shallow restrictive layers or if it has continued to flow deep into the subsurface. The depth of excavation varies depending on soil type and depth to hydraulic restricting layer, and is determined by an Idaho registered geologist, professional engineer, or professional soil scientist with experience in hydrogeologic investigations. Mounding is an indication that a mounding analysis is necessary.
2. Data Analysis:
 - a. Calculate and record the saturated hydraulic conductivity in inches per hour in thirty (30) minutes or one (1) hour increments until one (1) hour after the flow has stabilized.
 - b. Use statistical/trend analysis to obtain the hourly flow rate when the flow stabilizes. This would be the lowest hourly flow rate.
 - c. Apply appropriate factor of safety (FOS) to determine the site-specific design infiltration rate with a minimum FOS of two (2).

C. Basin Flooding Tests

Basin flooding tests shall be used to establish the permeability rates of bedrock beneath facilities in accordance to the procedures below.

1. Test Procedure

The test method is the following:

- a. A test basin meeting the following requirements shall be excavated within or immediately adjacent to the area of concern.
- b. The bottom area of the basin shall be the same size as the proposed facility infiltration area.
- c. The bottom of the basin should be made as level as possible so that high areas of rock do not project above the water level when the basin is flooded as prescribed below.
- d. If groundwater is observed within the test basin, this basin flooding test shall not be used.
- e. The test area shall be protected with non-woven filter fabric and one (1) foot of clean sand.
- f. Fill the test basin with exactly 12 inches of water above the top of the sand and record the time. Allow the basin to drain completely below the top of the sand. If the time required for the basin to drain completely is greater than 24 hours, the test shall be terminated and the limiting zone in question shall be considered to be a massive rock substratum.
- g. If the basin drains completely within 24 hours after the first flooding, immediately refill the basin to a depth of 12 inches above the top of the sand

and record the time. If the basin drains completely within 24 hours of the second filling, the limiting zone in question shall be considered to be fractured rock substratum. If water remains in the basin after 24 hours the limiting zone in question shall be considered to be a massive rock substratum.

2. Permeability Rate Determination

A design permeability rate shall only be used if the basin drains completely within 12 hours while performing 1.g. described above.

D. Other Allowable Methods

Other in-situ methods have been developed for determining field saturated hydraulic conductivity within the unsaturated zone of the soil. The following allowable methods may be used at the discretion of an Idaho registered geologist, professional engineer, or professional soil scientist provided they are appropriate for the site conditions.

- Double Ring Infiltrometer Test (ASTM D3385-03)
- Single Ring Infiltrometer Test (ASTM 3385-09)
- Well Permeameter Method (USBR Procedure 7300-89)
- Encased Borehole Test (ASTM D6391)

APPENDIX C

Operations & Maintenance Plan

Stormwater Facility Operation and Maintenance (O&M) Plan

1) Packaging and Format of O&M Plan

- a. Packaging – O&M Plans shall be submitted electronically in pdf format.
- b. Format – The Plan shall consist of the following:
 - i. Cover page – Project Title, Project Number, Date, Author and Signature
 - ii. Table of Contents
 - iii. Introduction
 - iv. Detailed Facility Description
 - v. Detailed Facility Maintenance and Operation Description
 - vi. Maintenance Schedule Table
 - vii. Attachment 1 – copy of construction plans
 - viii. Attachment 2 – copy of signed license agreement, if applicable

2) Introduction

- a. Purpose of plan
- b. General site description
- c. Site map with north arrow, scale, Site buildings, facilities, roads, etc. should be labeled

3) Detailed Facility Description

- a. Discussion of how facility is supposed to work
- b. Include detailed drawings of the facility which clearly denotes points of inflow and outflow, locations where maintenance is performed, etc.
- c. If facility is a manufactured structure, include manufacturers product information as an attachment

4) Detailed description of the maintenance activities that need to be performed. For each activity the following should be included:

- a. Name of maintenance activity
- b. Description of how and where activity is to be performed
- c. Discussion of who will perform activity (e.g. HOA, in-house staff, contracted third party, etc)
- d. Interval of maintenance (e.g. weekly, monthly, etc.)
- e. Any other pertinent information

5) Maintenance Log

Date	Maintenance Activity	Performed By	Description of Facility Conditions	Amount and Type of Material Removed	Comments

APPENDIX D

ACHD Basin Revegetation Guidance Manual

http://www.achdidaho.org/Documents/Engineering/Stormwater/ACHD_RevegationGuidanceManual_FINAL.pdf

APPENDIX E

Basin Inspection Checklist

Inspection Checklist for Basins & Swales (Revised 5/12/17)

Basin Location				
	Inspection 1	Inspection 2	Inspection 3	Inspection 4
Date & Time:				
Site Status:				
Approx. Date & Amount of Last Rainfall:				
Inspector				

Copy of this complete inspection checklist along with pictures to file

Type of Basin: Retention Detention Wet Swale

Provide a copy of the O&M Plan with this checklist.

Note: This form may be used for four different inspections

Maintenance Item	Pass/Fail				Comments
	1	2	3	4	
Irrigation (Daily)					N/A if not applicable
Control of nuisance water from lots and common areas to street					
Control of watering within basin landscape					
Retention/Detention Basins & Swales (Monthly, After Storms)					N/A if not applicable
Remove cobble or other non-draining material from sand infiltration areas.					
Remove sediment accumulation from sand infiltration areas, rake/till sand for positive drainage					
Remove litter and debris					
Low flow channels clear of obstructions					
Standing water or wet spots, source of water?					
Wet Basins (Monthly, After Major Storms)					N/A if not applicable
Undesirable vegetative growth					
Floating or floatable debris removal required					
Visible pollution					
Shoreline problem					

Inspection Checklist for Basins & Swales (Revised 5/12/17)

Maintenance Item	Pass/Fail				Comments
	1	2	3	4	
Other (specify)					
Basin Sediment Forebays (monthly, After Major Storms)					N/A if not applicable
Sedimentation noted					
Sediment cleanout when depth > 50% design depth					
Basin Primary Cell (Annual, After Major Storms)					
Vegetation and ground cover adequate					
Weed Control					
Unauthorized planting					
Slope protection/erosion					
Animal burrows					
Condition of overflow spillway (if applicable)					
Seeps/leaks					
Inlet pipe trash rack					
Endwalls/Headwalls					
Energy dissipation at inlet (riprap or concrete)					
Other (specify)					
Basin Riser and Principal Spillway Outfall (Annual)					N/A if Not Applicable
Type: <input type="checkbox"/> Reinforced Concrete <input type="checkbox"/> Corrugated pipe <input type="checkbox"/> Other					
Low flow orifice obstructed					
Low flow trash rack					
<ul style="list-style-type: none"> Debris removal necessary 					
<ul style="list-style-type: none"> Corrosion control 					
Weir trash rack maintenance					
<ul style="list-style-type: none"> Debris removal necessary 					
<ul style="list-style-type: none"> Corrosion control 					
Excessive sediment accumulation in or around riser					

Inspection Checklist for Basins & Swales (Revised 5/12/17)

Maintenance Item	Pass/Fail				Comments
	1	2	3	4	
Condition of riser and barrels					
<ul style="list-style-type: none"> • Minor spalling (<1") 					
<ul style="list-style-type: none"> • Major spalling (rebars exposed) 					
<ul style="list-style-type: none"> • Joint failures 					
<ul style="list-style-type: none"> • Water tightness 					
Outfall channels functioning					
Other (specify)					
Other (Monthly)					
Encroachment on pond or easement area					
Complaints from residents					
Aesthetics					
<ul style="list-style-type: none"> • Grass growing required 					
<ul style="list-style-type: none"> • Other (specify) 					
Any public hazards (specify)					
Constructed Wetland Area (Annual)					
Vegetation healthy and growing					
Evidence of invasive species					
Excessive sedimentation in wetland area					
Other (specify)					

APPENDIX F

Bioretention Soil Media Specifications

Bioretention Soil Media (BSM) Specifications

General Requirements

BSM should achieve a long-term, in-place infiltration rate between five (5) and eight (8) inches per hour.

The following composition includes the measurements for determining the BSM by volume:

BSM Composition	Sand	Sandy Loam			Compost
		Sand	Silt	Clay	
Volume	60%	20%			20%

A. Submittals

The Manufacturer shall submit a letter of verification that the products meet or exceed all requirements.

Tests shall be conducted no more than 180 days prior to the delivery date of the BSM to the project site. Batch-specific test results and certification will be required for projects installing more than 100 cubic yards of BSM.

The applicant should submit the following to ACHD for approval:

1. A one-gallon sample of mixed BSM.
2. Grain size analysis results of the sand component, sandy loam soil component and compost component performed in accordance with American Society for Testing and Materials (ASTM) D422, Standard Test Method for Particle Size Analysis of Soils.
3. Organic matter content test results of compost. Organic matter content tests should be performed in accordance with ASTM F 1647, Standard Test Methods for Organic Matter Content of Athletic Field Rootzone Mixes or Testing Methods for the Examination of Compost and Composting (TMECC) 05.07A, Loss-On-Ignition Organic Matter Method.
4. Constant head permeability results of the mixed BSM in accordance with ASTM D2434, Standard Test Method for Permeability of Granular Soils (Constant Head) conducted on a minimum of two samples with a 6-inch mold and vacuum saturation.
5. Information about the testing laboratory(ies) including:
 - a. Name of laboratory(ies)
 - b. Contact person(s)
 - c. Address(es)
 - d. Phone contact(s)
 - e. Email address(es)
 - f. Qualifications of laboratory(ies), including use of ASTM and U.S. Department of Agriculture(USDA) method of standards

B. Sand Specifications

Sand should be thoroughly washed prior to delivery and free of wood, waste, and coatings such as clay, stone dust, carbonate, or any other deleterious material.

Sand for BSM should be analyzed by a qualified lab using #200, #100, #50, #30, #16, #8, #4, and 3/8-inch sieves (ASTM D422 or as approved by ACHD).

C. Sandy Loam Soil Specifications

Sandy loam soil for the BSM shall be tested for phosphorus content: 15-60 mg/kg P by Mehlich3 or Olsen method.

Sandy loam soil should comply with the following specifications by weight based on ASTM D422:

- 70-90 percent sand
- 0–30 percent silt
- 2–15 percent clay

Note: these ranges were selected from the USDA soil textural classification for a sandy loam, such that clay content does not exceed 15 percent of sandy loam.

D. Compost Specifications

Compost should be a well-decomposed, stable, weed-free organic matter source derived from waste materials including yard debris, wood wastes or other organic materials, not including manure or biosolids from industrial wastewater or sewage sludge.

A qualified lab should analyze compost using No. 200 and 1/2-inch sieves (ASTM D422 or as approved by ACHD), and meet the following gradation:

Sieve Size	Percent Passing (by weight)	
	Min.	Max.
1/2 inch	100	100
No. 200	0	5

Compost should comply with the following requirements:

Parameter	Method	Requirement	Units
Bulk Density	-	1080 - 1400	dry lbs/cubic yd
Moisture Content	Gravimetric	35%–65%	dry solids
Organic Matter	ASTM F 1647 Standard Test Methods for Organic Matter Content of Athletic Field Rootzone Mixes or Testing Methods for the Examination of Compost and Composting (TMECC) 05.07A, "Loss-On-Ignition Organic Matter Method."	35%–65	dry weight
Inert Material/Physical Contaminants		<1%	Dry weight
pH	Saturation Paste	6.0–8.0	
Carbon:Nitrogen Ratio	-	15:1–35:1	
Maturity/Stability	TMECC05.05 or Solvita®*	> 5	Index value

Pathogens			
Salmonella	-	< 3	MPN per 4 g
Fecal Coliform		< 1000	MPN per 1 g

*Solvita is a measurement system for carbon dioxide (CO2) and ammonia (NH3). The results can be used to assess soil health (biology) and compost maturity (CO2+NH3 gas emissions).

E. BSM Specifications

BSM shall be free of roots, clods, stones larger than 3-inches in the greatest dimension, pockets of coarse sand, noxious weeds, sticks, lumber, brush, and other litter. It shall not be infested with nematodes or undesirable disease-causing organisms such as insects and plant pathogens. BSM shall be friable and have sufficient structure in order to give good aeration to the soil.

Gradation Limit: The definition of the BSM should be the following USDA classification scheme by weight:

- a. Sand: 85–90 percent
- b. Silt: 10 percent maximum
- c. Clay: 5 percent maximum

The final BSM should meet the following standards. Testing results from the following specifications shall be submitted for approval prior to BSM acceptance.

Parameter	Method	Requirement	Units
Organic Matter	Loss on Ignition	2%-5%	Dry weight
pH	Saturation Paste	6.0-8.0	
Cation Exchange Capacity (CEC)		≥ 5	meq/100 g of dry soil

F. BSM Testing

The Contractor shall not place any soils or soil mixes until the Inspector has reviewed and confirmed the following:

- Soil mix delivery ticket(s). Delivery tickets shall show that the full delivered amount of soil matches the product type, volume and Manufacturer named in the submittals.
- Visual match with submitted samples. Delivered product will be compared to the submitted sample, to verify that it matches the submitted sample.

The Inspector may inspect any loads of soil and stop placement if it is determined that the delivered soil does not appear to match the submittals; and require sampling and testing of the delivered soil, before authorizing soil placement. All testing costs shall be the responsibility of the Contractor.

G. BSM Mixing and Placement

1. The following practices shall be followed to protect the long-term functionality of the facility:

a. BSM should be mixed prior to being delivered to the site.

- b. Operate equipment adjacent to the facility. Equipment operation within the facility shall be avoided to prevent soil compaction. If machinery must operate in the facility, use lightweight, low ground-contact pressure equipment with turf type tires or wide-track loaders.
 - c. Place soil in 6- to 12-inch lifts with machinery adjacent to the facility (to ensure equipment is not driven across soil). If working within the facility, to avoid over-compacting, place first lifts at far end from entrance and place backwards towards the entrance.
 - d. Allow BSM lifts to settle naturally, lightly water to provide settlement and natural compaction between lifts. After lightly watering, allow soil to dry between lifts. After all lifts are placed, wait a few days to check for settlement, and add additional media as needed.
 - e. Vehicular traffic and construction equipment shall not drive on, move onto, or disturb the BSM once placed and water-compacted.
 - f. Rake bioretention soil as needed to level out. Verify BSM elevations before applying mulch or installing plants.
2. Facilities should not be used as temporary sediment control facilities, unless installation of all bioretention-related materials are withheld towards the end of construction, allowing the temporary use of the location as a sediment control facility, and appropriate excavation of sediment occurs prior to installation of bioretention materials.

APPENDIX G

Detail 1 Beehive Overflow

Detail 2 Flow Spreader for Basins and Swales

Detail 3 Access Roads and Turnaround Detail

Detail 4 Stormwater Basin Standards

Detail 5 Borrow Ditch

Detail 6 Drop Inlet Layout Tolerances

Detail 7 Seepage Bed/Sewer & Water Service Conflict Options

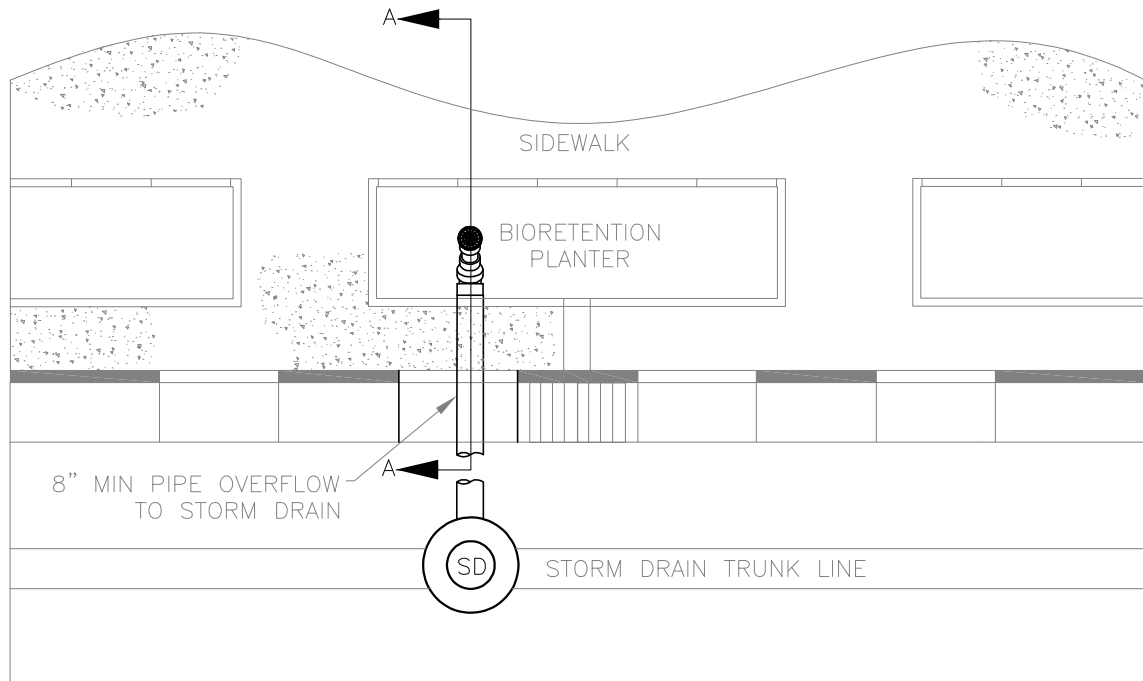

**PLAN
N.T.S.**

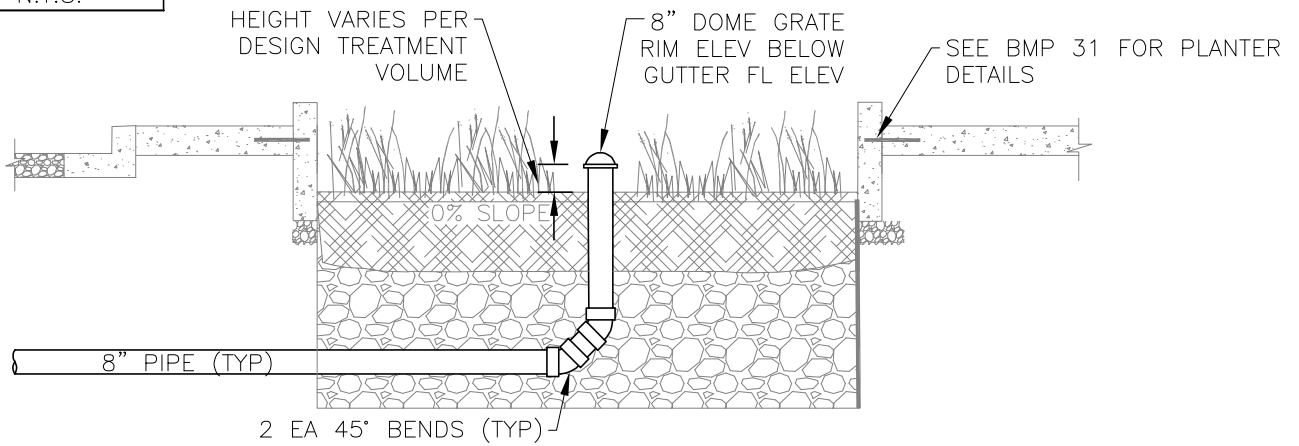

**SECTION A-A
N.T.S.**

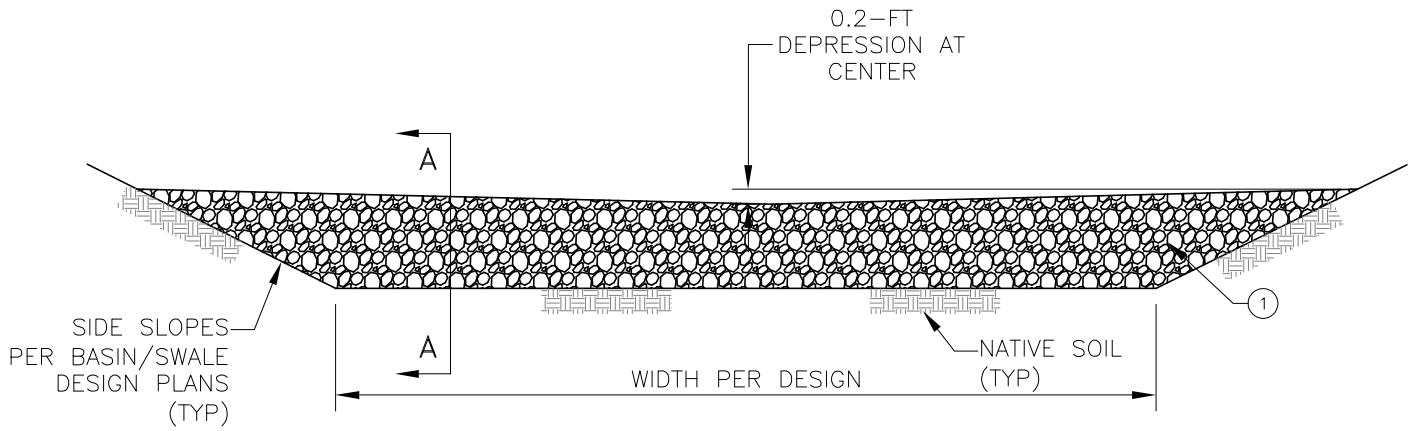

**SECTION
N.T.S.**

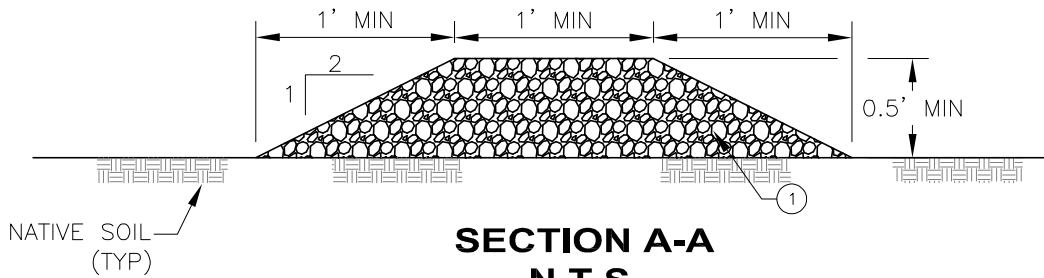

**SECTION A-A
N.T.S.**

LEGEND:

- ① 3"-6" CLEAN ANGULAR RIVER ROCK (ISPC SECTION 801)

NOTES:

1. FLOW SPREADER SHALL BE USED WHEN LONGITUDINAL GRADE >1% FOR 100- FEET OR MORE IN BASIN OR SWALE.

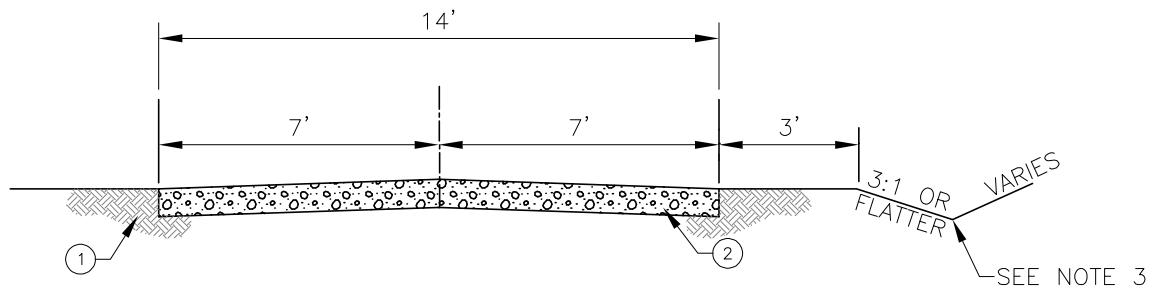

**TYPE 1
N.T.S.**

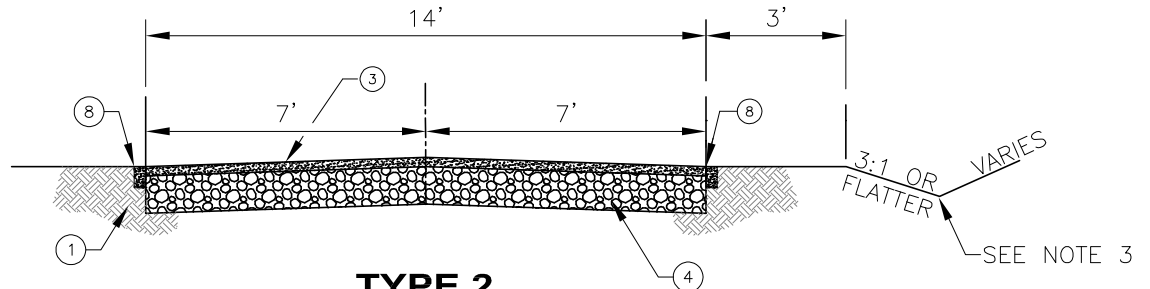

**TYPE 2
N.T.S.**

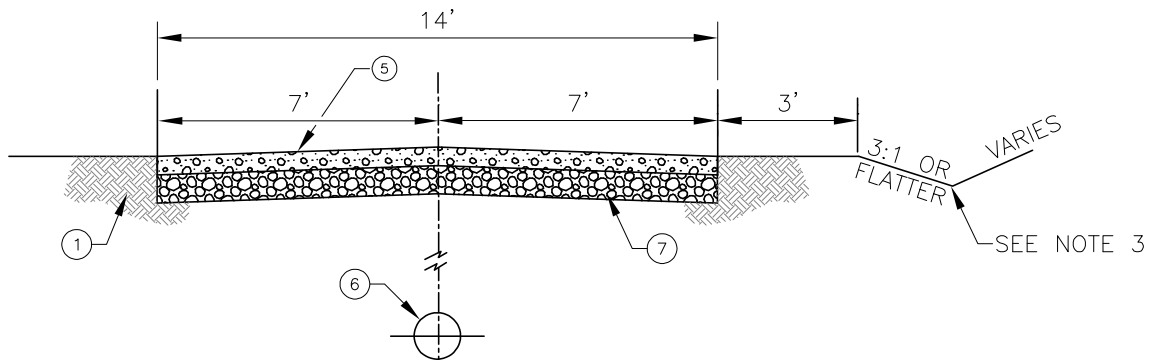

**TYPE 3
N.T.S.**

LEGEND:

- ① NATIVE SOIL
- ② 8" OF 3/4" MINUS CRUSHED AGGREGATE COMPACTED TO 95% DRY DENSITY
- ③ GRASSCRETE/GRASSPAVE OR APPROVED EQUAL
- ④ 10" OF 6" MINUS PITRUN GRAVEL COMPACTED TO 95% DRY DENSITY
- ⑤ 3" OF 3/4" MINUS CRUSHED AGGREGATE COMPACTED TO 95% DRY DENSITY
- ⑥ PROPOSED PIPE LINE
- ⑦ 8" OF 6" MINUS PITRUN GRAVEL COMPACTED TO 95% DRY DENSITY
- ⑧ DELINEATE EDGE WITH LANDSCAPE CURB OR PLANTS

NOTES:

- 1. PROVIDE 2% CROWN ON ALL ROAD TYPES
- 2. IF ROADWAY PROVIDES FIRE ACCESS, WIDTH MUST BE AT LEAST 20' WITH 10" OF BASE MATERIAL OR PER FIRE DEPARTMENT REQUIREMENTS, WHICHEVER IS MORE RESTRICTIVE
- 3. BORROW DITCHES SHALL HAVE A 3:1 MAX FORESLOPE WITH 4:1 SLOPE RECOMMENDED. THE BACK SLOPE SHALL BE 1:1 MAX WITH 4:1 RECOMMENDED

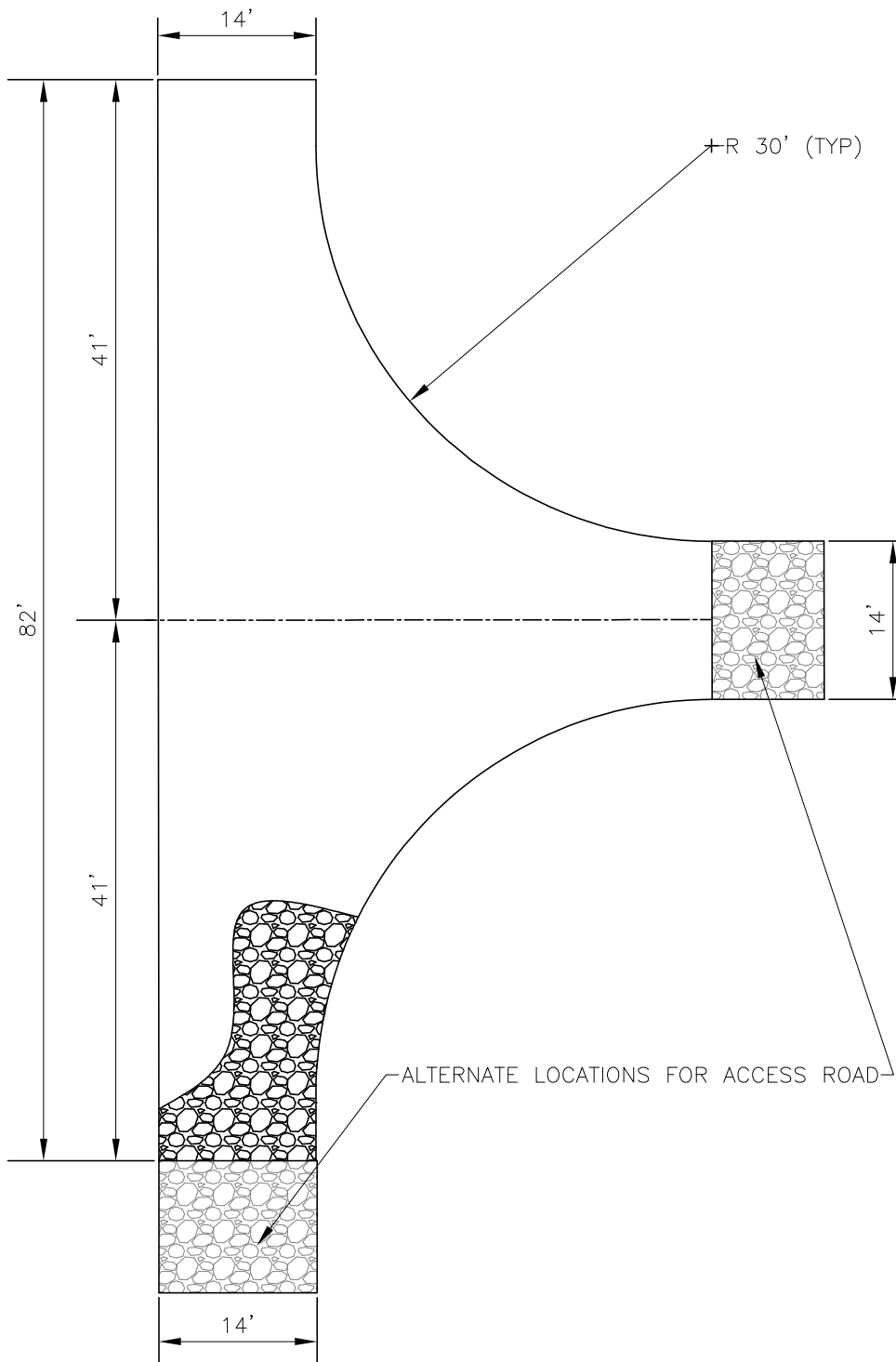

**PLAN
N.T.S.**

NOTES:

1. IF ROADWAY PROVIDES FIRE ACCESS, MINIMUM WIDTH IS 20' AND MINIMUM CURVE RADIUS IS 60', UNLESS OTHERWISE SPECIFIED.

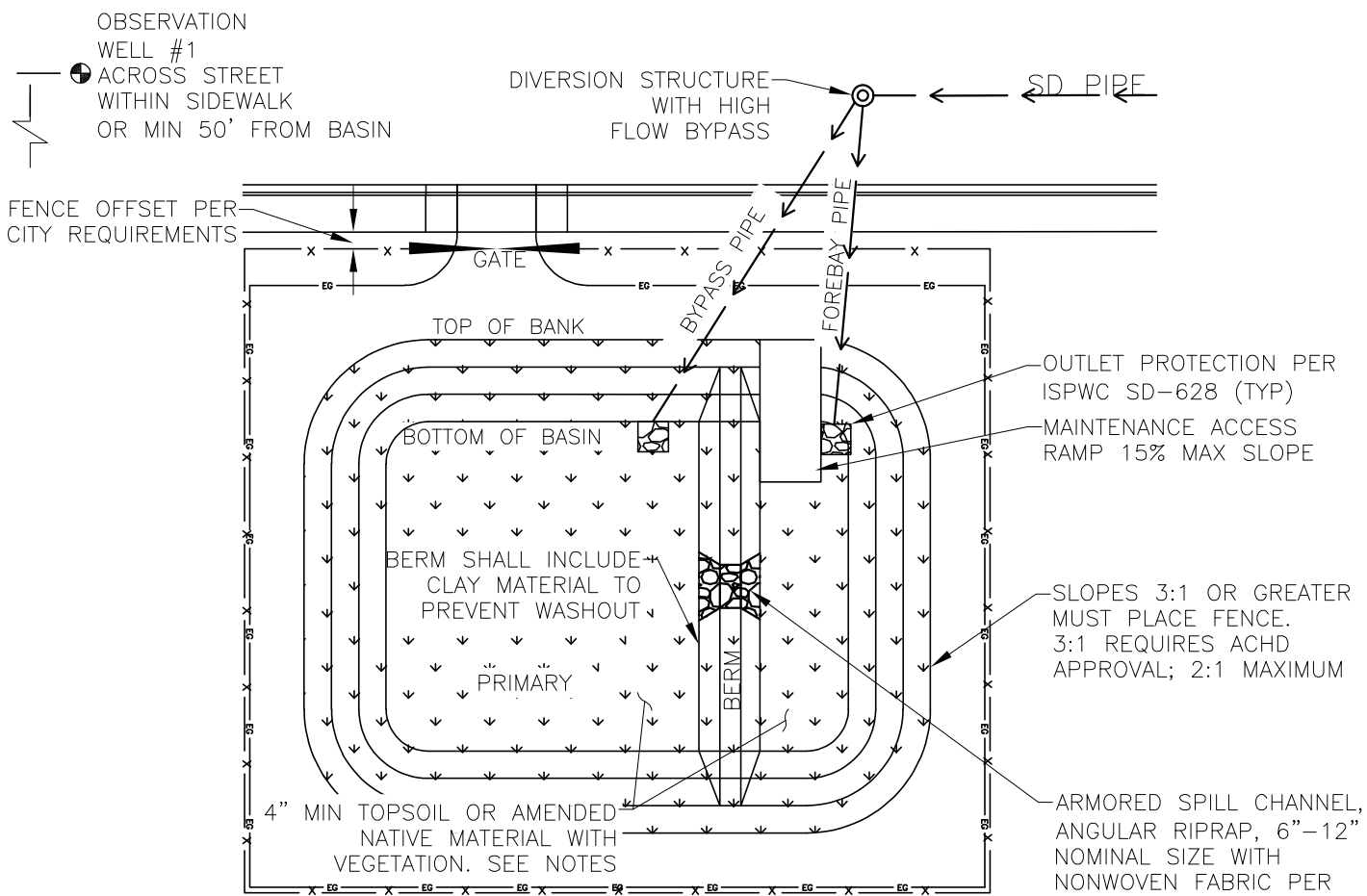

**PLAN
N.T.S.**

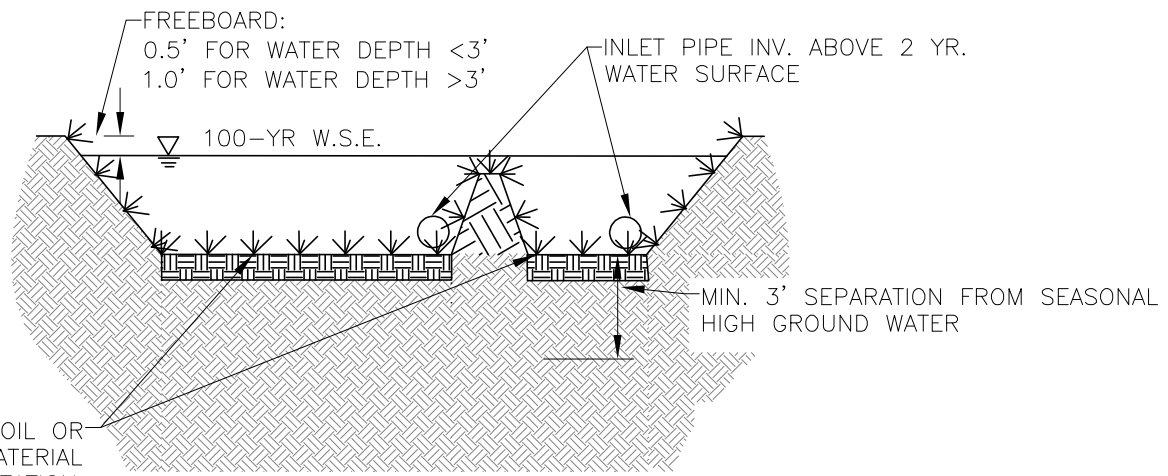

**SECTION
N.T.S.**

NOTES:
1. SEE SHEET 2 OF 2 FOR STORMWATER BASIN NOTES

STORMWATER BASIN NOTES:

1. ALL BASINS TO BE VEGETATED, INCLUDING SLOPES AND BOTTOM. SLOPES SHALL HAVE IRRIGATED TURF GRASS, DRY LAND GRASS, OR WETLAND VEGETATION AS APPROPRIATE. NO IRRIGATION ON BASIN FLOOR. NO WOODY VEGETATION BELOW 100-YEAR WATER SURFACE OR WITHIN 10' OF EMBANKMENT SPILLWAY, PIPES, OR STRUCTURES. SEE ACHD STORMWATER MANAGEMENT BASIN REVEGETATION GUIDANCE MANUAL AND SPECIFIC BMP'S FOR ADDITIONAL VEGETATION REQUIREMENTS.
2. EXCAVATE AND SCARIFY SUBSOIL BEFORE TOPSOIL/AMENDED SOIL IS PLACED. VEGETATE AFTER CONTRIBUTING DRAINAGE AREA HAS SITE SEDIMENT & EROSION CONTROL MEASURES IN PLACE.
3. FOREBAY IS SIZED TO CONTAIN 10% OF TOTAL BASIN VOLUME.
4. AREAS DESIGNATED FOR BASINS SHALL BE CLEARED, GRUBBED AND STRIPPED OF TOPSOIL. TOPSOIL SHALL BE STOCKPILED AND USED AT FINAL GRADING TO ESTABLISH VEGETATION.
5. FILL MATERIALS FOR EMBANKMENT, INCLUDING BERMS, SHALL CONFORM TO UNIFIED SOIL CLASSIFICATION, SC, CH, OR CL AND MUST HAVE AT LEAST 30% PASSING THE #200 SIEVE. AREAS ON WHICH FILL IS TO BE PLACED SHALL BE SCARIFIED PRIOR TO PLACEMENT OF FILL. EMBANKMENT FILL SHALL MEET ISPWC CLASS C COMPACTION REQUIREMENTS. CONSIDERATION MAY BE GIVEN TO THE USE OF OTHER MATERIALS IN THE EMBANKMENT IF DESIGNED BY A GEOTECHNICAL ENGINEER.
6. FOR EMBANKMENT HEIGHTS GREATER THAN 10', REFER TO IDAHO DEPARTMENT OF WATER RESOURCES REQUIREMENTS.
7. AN EMERGENCY SPILLWAY IS ENCOURAGED WHERE POSSIBLE.
8. ALL EXPOSED PIPES TO BASINS SHALL BE RCP OR HAVE AN END SECTION WITH UNEXPOSED PIPE TO RESIST DEGRADATION FROM WEATHER.
9. 14' WIDE MIN GRAVEL ACCESS ROAD AS NEEDED TO STRUCTURES WITH TURNAROUND OR LOOP WHEN LENGTH \geq 50-FT. ROAD MAXIMUM GRADE OF 10%, MAXIMUM 15% GRADE FOR RAMPS TO BASIN BOTTOM (RAMP REQUIRED WHEN BASIN BOTTOM AREA EXCEEDS 1,500 S.F.) 30' MINIMUM INSIDE CURVE RADIUS.
10. A LICENSE AGREEMENT IS REQUIRED FOR HOA OWNED BASINS.
11. SAFETY BENCH REQUIREMENTS. THE PERIMETER OF ALL WET BASINS SHALL HAVE A MINIMUM 6-FOOT WIDE FLAT BENCH 1.5- FEET BELOW THE SEASONAL HIGH WATER SURFACE ELEVATION. BASIN SLOPE BETWEEN THE TOP OF THE BANK AND BENCH SHALL NOT EXCEED 4:1. SEE DETAIL BELOW AND BMP 13.

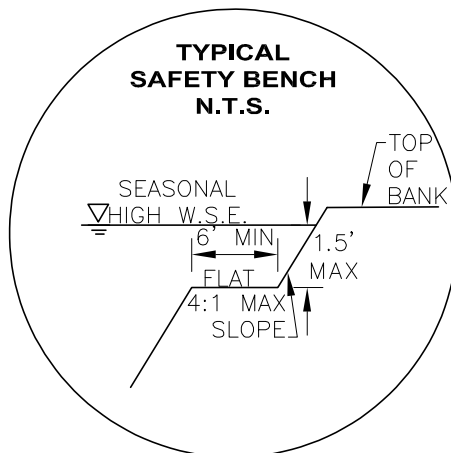

NOTES FOR ACHD OWNED BASINS:

1. A MIN 4-FT TALL FENCE WITH TOP BAR IS REQUIRED PER ACHD POLICY SECTION 8202.17.10. GATES SHALL BE 20' WIDE.
2. DROUGHT TOLERANT NATIVE PLANTS ARE REQUIRED. HYDROSEED, MULCH AND TACKIFY BANKS. ANY LANDSCAPING AND SPRINKLERS SHALL BE NEGOTIATED WITH THE CITY THROUGH A COST SHARE AGREEMENT.

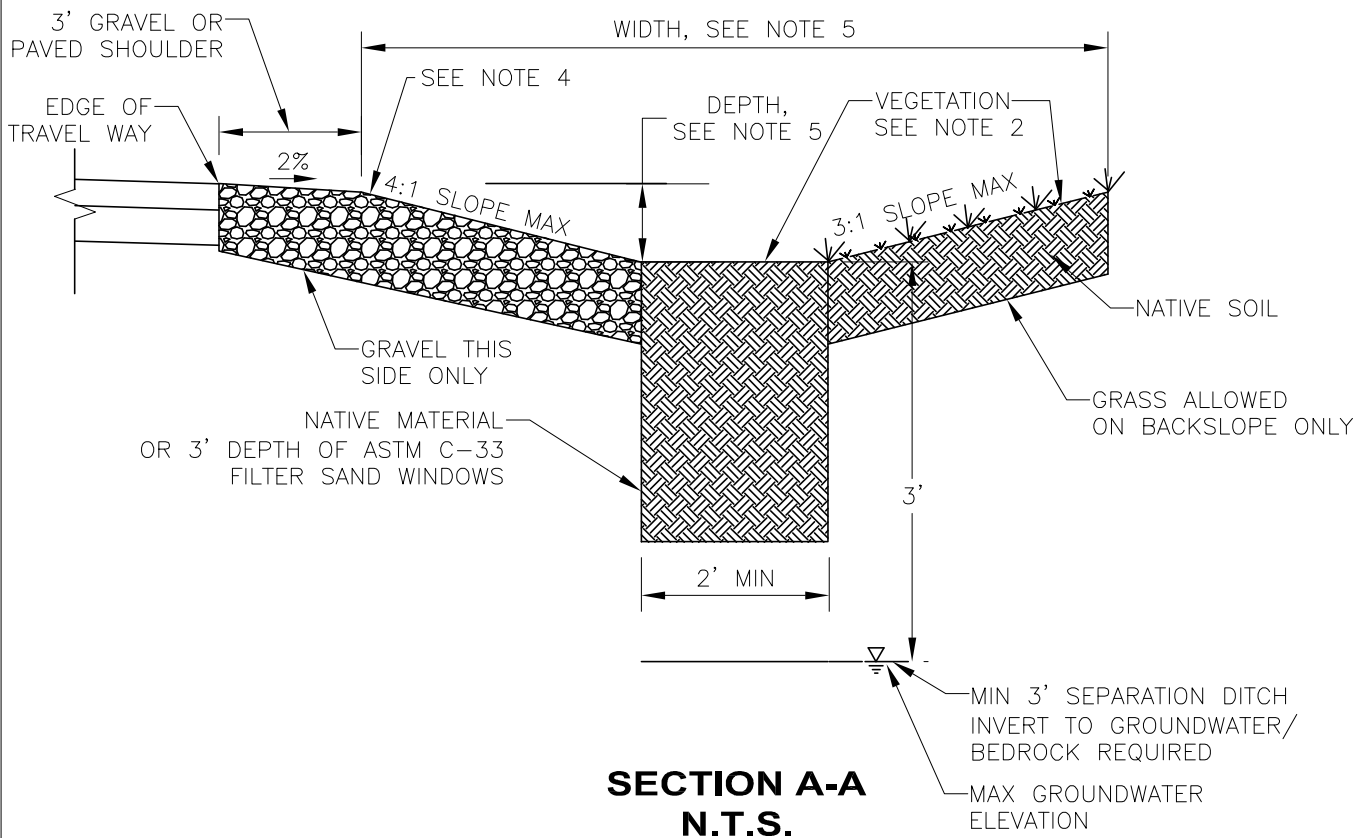
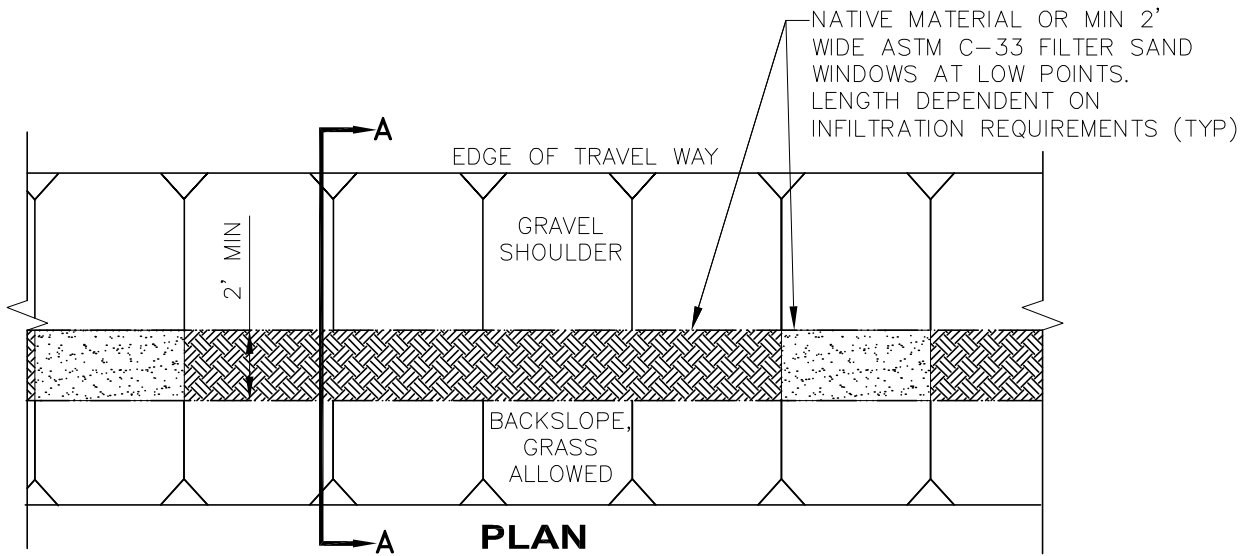

NOTES:

1. BORROW DITCHES SHALL BE DESIGNED TO CONVEY RUNOFF TO A DISCHARGE POINT OR INFILTRATE STORMWATER. SIZE FOR 100-YEAR DESIGN STORM.
2. DROUGHT TOLERANT PLANT SPECIES AND/OR ASTM C-33 SAND WINDOWS IN INVERT. BACKSLOPE OF BORROW DITCH MAY HAVE GRASS.
3. IF SAND WINDOWS ARE USED IN LIEU OF CONTINUOUS SAND TRENCH, PROVIDE DRAINAGE CALCULATIONS TO SHOW INFILTRATION OF 90% VOLUME IN 48-HOURS IS MET.
4. 4:1 MAX SLOPE OF GRAVEL SHOULDER FOR ROADS ≥ 45 MPH, 3:1 MAX SLOPE OF GRAVEL SHOULDER FOR ROADS < 45 MPH
5. BORROW DITCH WIDTH AND DEPTH VARIES BASED ON SIZING REQUIREMENTS
6. CURBING MAY BE REQUIRED
7. USE INTENDED FOR UNDEVELOPED, RURAL ARTERIALS

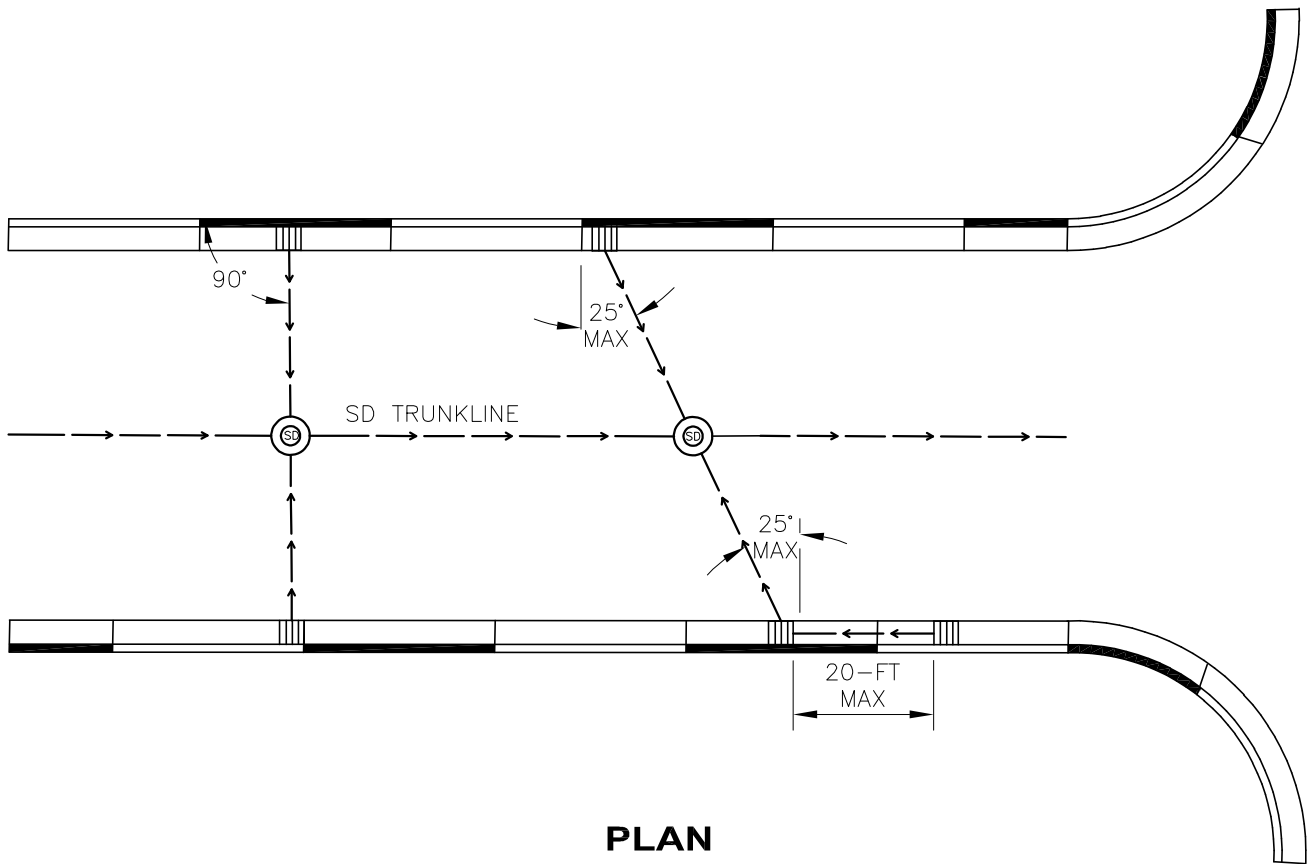

**PLAN
N.T.S.**

NOTES:

1. STORM DRAIN PIPE LATERALS SHALL BE PERPENDICULAR TO THE CURB (DI FACE) OR NO GREATER THAN A 25° ANGLE
2. MAXIMUM PIPE LATERAL LENGTH FROM SHORT END OF DI IS 20- FEET WITH 12-IN MAX PIPE SIZE
3. PIPES >12-IN SHALL CONNECT TO DI FACE
4. STORM DRAIN PIPES SHALL BE LOCATED WITHIN THE APPROVED UTILITY CORRIDOR OR APPROVED BY A WRITTEN VARIANCE

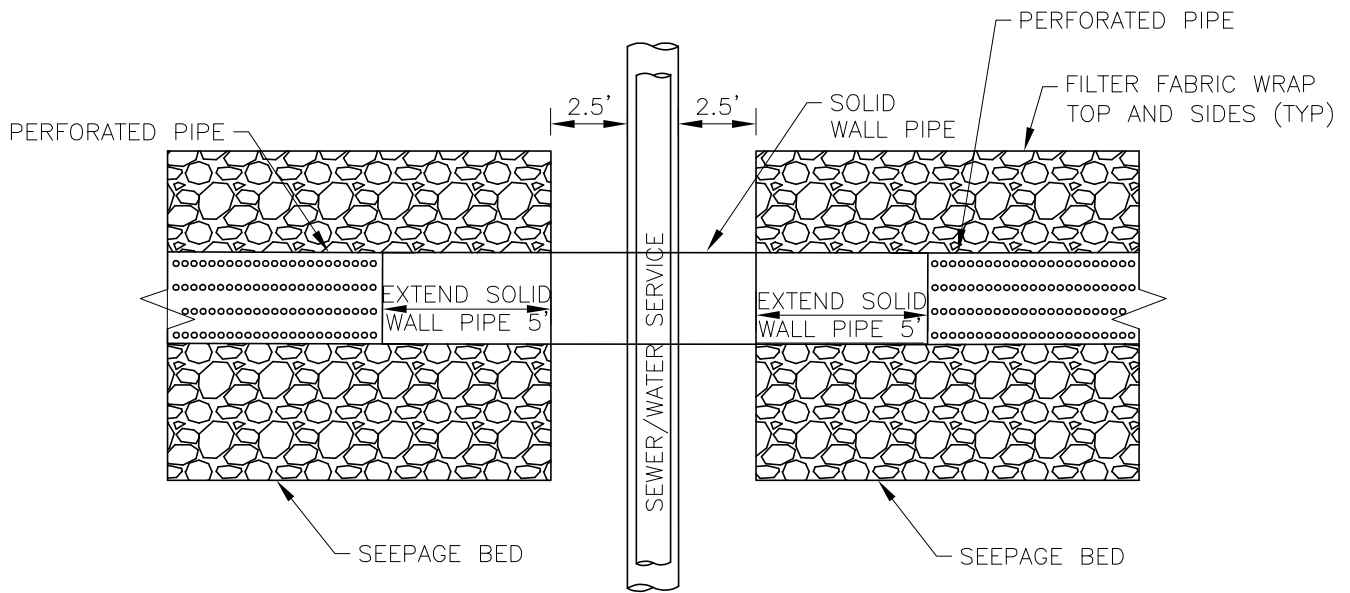

OPTION 1: BREAK BED

**PLAN
N.T.S.**

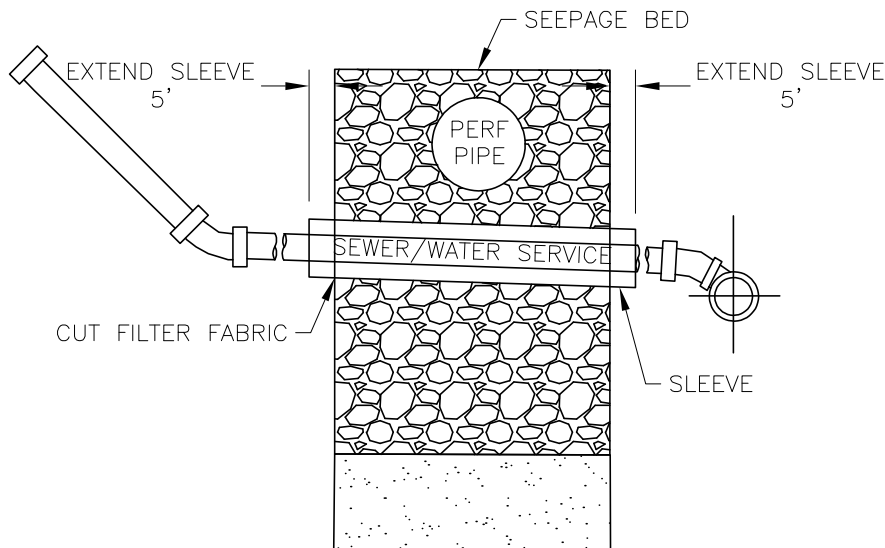

OPTION 2: SLEEVE LINE

**SECTION
N.T.S.**

NOTES

1. OPTION 1 REQUIRES SEEPAGE BED LENGTH TO BE INCREASED BY GAP LENGTH